



HANDBOOK

# Redbox RB-AEC Acoustic Echo Canceller



## SONIFEX

Manufacturers of audio & video  
products for radio & TV broadcasters

This handbook is for use with the following product:

Redbox RB-AEC Acoustic Echo Canceller

Stock Code: 30-285

Revision 1.04, June 2015

©Sonifex Ltd, 2015

All Rights Reserved

Sonifex Ltd, 61, Station Road, Irthlingborough,  
Northants, NN9 5QE, England.

Tel: +44 (0)1933 650 700

Fax: +44 (0)1933 650 726

Email: [sales@sonifex.co.uk](mailto:sales@sonifex.co.uk)

Website: <http://www.sonifex.co.uk>

Information in this document is subject to change without notice and does not represent a commitment on the part of the vendor. Sonifex Ltd shall not be liable for any loss or damage whatsoever arising from the use of information or any error contained in this manual.

No part of this manual may be reproduced or transmitted in any form or by any means, electronic or mechanical, including photocopying, recording, information storage and retrieval systems, for any purpose other than the purchaser's personal use, without the express written permission of Sonifex Ltd. Unless otherwise noted, all names of companies, products and persons contained herein are part of a completely fictitious adaptation and are designed solely to document the use of Sonifex product.

Made in the UK by **SONIFEX**

# Contents

## Product Warranty - 2 Year

### Sonifex Warranty & Liability Terms & Conditions

1. Definitions
2. Warranty

### Unpacking Your Product

### Repairs & Returns

## CE Declaration of Conformity and Approval Information

## Safety & Installation of Mains Operated Equipment

### Voltage Setting Checks

### Fuse Rating

### Power Cable & Connection

### WEEE Directive

### RoHS Directive

### Atmosphere

### Fitting Redboxes

## Introduction

- Category
- Product Function
- Typical Applications
- Features

### System Block Diagram

### Operation of the RB-AEC

### Front Panel Controls and Indicators

- Power LED
- Reset Button

### Rear Panel Connections and Controls

- Inputs
- Outputs
- Settings DIPSwitch
- GPIO Connector
- Ethernet Port
- Mains Power

## Applications

### How to Remove Delayed Presenter's Audio From Their Earpiece

- The Problem:
- The Solution:

### How to Remove Delayed Caller Audio From Telephone Line

- The Problem:

The Solution:	8
<b>Calibration</b>	<b>9</b>
<b>Webserver &amp; Unit Discovery</b>	<b>10</b>
Running The Webserver	10
<b>Home Page</b>	<b>11</b>
Far End and Near End Input Type	11
Adaption Status	11
Sample Rate	12
Offset	12
Reset Coefficients	12
Save Coefficients	12
Load Saved Coefficients Now	12
Load Saved Coefficients on Startup	12
Far End Silence Detect Threshold:	12
Enable Noise Gate:	12
Noise Gate Threshold:	13
Noise Gate Release Time:	13
<b>Network Page</b>	<b>13</b>
<b>Network Settings</b>	<b>13</b>
Host Name	13
Static IP Address	14
Static Subnet Mask	14
Gateway IP Address	14
Dynamic Addressing	14
<b>Device Info Page</b>	<b>14</b>
<b>Update Page</b>	<b>15</b>
Update	15
<b>Technical Specification For RB-AEC</b>	<b>16</b>
<b>Figures</b>	
Fig 1-1: The RB-AEC Acoustic Echo Canceller	1
Fig 1-2: The RB-AEC Operational Block Diagram	2
Fig 1-3: The RB-AEC Functional Block Diagram	3
Fig 2-1: The RB-AEC Front Panel	4
Fig 2-2: The RB-AEC Rear Panel	5
Fig 4-1: The RB-AEC Sonifex Service Discovery Tool	10
Fig 4-2: The RB-AEC Webserver Interface - Home	11
Fig 4-3: The RB-AEC Webserver Interface - Configuration	12
Fig 4-4: The RB-AEC Webserver Interface - Network	13
Fig 4-5: The RB-AEC Webserver Interface - Device Info	14
Fig 4-6: The RB-AEC Webserver Interface - Update	15

# SONIFEX

## Register Online for an Extended 2 Year Warranty

As standard, Sonifex products are supplied with a 1 year back to base warranty.

If you register the product online, you can increase your product warranty to 2 years and we can also keep you informed of any product design improvements or modifications.

To register your product, please go online to [www.sonifex.co.uk/register](http://www.sonifex.co.uk/register)

## Product Warranty - 2 Year

As standard, Sonifex products are supplied with a 1 year back to base warranty. In order to register the date of purchase and so that we can keep you informed of any product design improvements or modifications, it is important to complete the warranty registration online. Additionally, if you register the product on the Sonifex website within 30 days of purchase, you can increase your product warranty to 2 years. Go to the Sonifex website at: <http://www.sonifex.co.uk/technical/register/index.asp> to apply for your 2 year warranty.

**Note:** For your own records the product serial number is recorded on the CE certification page of this handbook.

## Sonifex Warranty & Liability Terms & Conditions

### 1. Definitions

‘the Company’ means Sonifex Ltd and where relevant includes companies within the same group of companies as Sonifex Limited.

‘the Goods’ means the goods or any part thereof supplied by the Company and where relevant includes: work carried out by the Company on items supplied by the Purchaser; services supplied by the Company; and software supplied by the Company.

‘the Purchaser’ means the person or organisation who buys or has agreed to buy the Goods.

‘the Price’ means the Price of the Goods and any other charges incurred by the Company in the supply of the Goods.

‘the Warranty Term’ is the length of the product warranty which is usually 12 months from the date of despatch; except when the product has been registered at the Sonifex website when the Warranty Term is 24 months from the date of despatch.

‘the Contract’ means the quotation, these Conditions of Sale and any other document incorporated in a contract between the Company and the Purchaser.

This is the entire Contract between the parties relating to the subject matter hereof and may not be changed or terminated except in writing in accordance with the provisions of this Contract. A reference to the consent, acknowledgement, authority or agreement of the Company means in writing and only by a director of the Company.

### 2. Warranty

- (a) The Company agrees to repair or (at its discretion) replace Goods which are found to be defective (fair wear and tear excepted) and which are returned to the Company within the Warranty Term provided that each of the following are satisfied:
- (i) notification of any defect is given to the Company immediately upon its becoming apparent to the Purchaser;
  - (ii) the Goods have only been operated under normal operating conditions and have only been subject to normal use (and in particular the Goods must have been correctly connected and must not have been subject to high voltage or to ionising radiation and must not have been used contrary to the Company’s technical recommendations);
  - (iii) the Goods are returned to the Company’s premises at the Purchaser’s expense;
  - (iv) any Goods or parts of Goods replaced shall become the property of the Company;
  - (v) no work whatsoever (other than normal and proper maintenance) has been carried out to the Goods or any part of the Goods without the Company’s prior written consent;

- (vi) the defect has not arisen from a design made, furnished or specified by the Purchaser;
  - (vii) the Goods have been assembled or incorporated into other goods only in accordance with any instructions issued by the Company;
  - (viii) the defect has not arisen from a design modified by the Purchaser;
  - (ix) the defect has not arisen from an item manufactured by a person other than the Company. In respect of any item manufactured by a person other than the Company, the Purchaser shall only be entitled to the benefit of any warranty or guarantee provided by such manufacturer to the Company.
- (b) In respect of computer software supplied by the Company the Company does not warrant that the use of the software will be uninterrupted or error free.
- (c) The Company accepts liability:
- (i) for death or personal injury to the extent that it results from the negligence of the Company, its employees (whilst in the course of their employment) or its agents (in the course of the agency);
  - (ii) for any breach by the Company of any statutory undertaking as to title, quiet possession and freedom from encumbrance.
- (d) Subject to conditions (a) and (c) from the time of despatch of the Goods from the Company's premises the Purchaser shall be responsible for any defect in the Goods or loss, damage, nuisance or interference whatsoever consequential economic or otherwise or wastage of material resulting from or caused by or to the Goods. In particular the Company shall not be liable for any loss of profits or other economic losses. The Company accordingly excludes all liability for the same.
- (e) At the request and expense of the Purchaser the Company will test the Goods to ascertain performance levels and provide a report of the results of that test. The report will be accurate at the time of the test, to the best of the belief and knowledge of the Company, and the Company accepts no liability in respect of its accuracy beyond that set out in Condition (a).
- (f) Subject to Condition (e) no representation, condition, warranty or other term, express or implied (by statute or otherwise) is given by the Company that the Goods are of any particular quality or standard or will enable the Purchaser to attain any particular performance or result, or will be suitable for any particular purpose or use under specific conditions or will provide any particular capacity, notwithstanding that the requirement for such performance, result or capacity or that such particular purpose or conditions may have been known (or ought to have been known) to the Company, its employees or agents.
- (g) (i) To the extent that the Company is held legally liable to the Purchaser for any single breach of contract, tort, representation or other act or default, the Company's liability for the same shall not exceed the price of the Goods.
- (ii) The restriction of liability in Condition (g)(i) shall not apply to any liability accepted by the Seller in Condition (c).
- (h) Where the Goods are sold under a consumer transaction (as defined by the Consumer Transactions (Restrictions on Statements) Order 1976) the statutory rights of the Purchaser are not affected by these Conditions of Sale.

## Unpacking Your Product

Each product is shipped in protective packaging and should be inspected for damage before use. If there is any transit damage take pictures of the product packaging and notify the carrier immediately with all the relevant details of the shipment. Packing materials should be kept for inspection and also for if the product needs to be returned.

The product is shipped with the following equipment so please check to ensure that you have all of the items below. If anything is missing, please contact the supplier of your equipment immediately.

Item	Quantity
Product Unit	1
IEC Mains lead fitted with moulded mains plug	1
Handbook and warranty card	1

If you require a different power lead, please let us know when ordering the product.

## Repairs & Returns

Please contact Sonifex or your supplier if you have any problems with your Sonifex product. Email [technical.support@sonifex.co.uk](mailto:technical.support@sonifex.co.uk) for the repair/upgrade/returns procedure, or for support & questions regarding the product operation.

# CE Declaration of Conformity and Approval Information



This document certifies that the Sonifex product that you have purchased is compliant with CE specifications. If you would like further information on compliance of all Sonifex products, please check the website at the address above where full information is available.

**Sonifex Limited hereby certify that the following product with serial number shown has been designed and manufactured in accordance with the following specifications :**

**EMC:** EN 55103-1: 1997 Electromagnetic Compatibility.  
Limits of disturbance for audio apparatus for professional use  
For use in environments 1 to 4.

EN 55103-2: 1997 Electromagnetic Compatibility.  
Limits of disturbance for audio apparatus for professional use  
For use in environments 1 to 4.

**Safety:** EN 60950: 1992 Safety of Information Technology Equipment  
Including Electrical Business Equipment.

**Hybrid** BS6301, BS7002, BS415, CTR21,

**Approvals:** R&TTE directive (1999/5/EC)

Product: \_\_\_\_\_

Serial No: \_\_\_\_\_

The Reference Technical Justification File for this product is available at Sonifex Ltd.

**Authorised By:**

Name: Chris Stills

Position: Technical Director

Date of Issue: 01 June 2015

Signature:

# SONIFEX

61 Station Road • Irthlingborough • Northants  
NN9 5QE • United Kingdom • www.sonifex.co.uk  
T: +44 (0)1933 650 700 • F: +44 (0)1933 650 726



## Safety & Installation of Mains Operated Equipment

There are no user serviceable parts inside the equipment. If you should ever need to look inside the unit, always disconnect the mains supply before removing the equipment covers. The cover is connected to earth by means of the fixing screws. It is essential to maintain this earth/ground connection to ensure a safe operating environment and provide electromagnetic shielding.

### Voltage Setting Checks





Ensure that the machine operating voltage is correct for your mains power supply by checking the box in which your product was supplied. The voltage is shown on the box label. The available voltage settings are 115V, or 230V. Please note that all products are either switchable between 115V and 230V, or have a universal power supply.

### Fuse Rating

The product is supplied with a single fuse in the live conducting path of the mains power input. For reasons of safety it is important that the correct rating and type of fuse is used. Incorrectly rated fuses could present a possible fire hazard, under equipment fault conditions. The active fuse is fitted on the outside rear panel of the unit.

## Power Cable & Connection

An IEC power connector is supplied with the product which has a moulded plug attached – this is a legal requirement. The mains lead is automatically configured for the country that the product is being sent to, from one of:

Territory	Voltage	IEC Lead Type	Image
UK & Middle East	230V	UK 3 pin to IEC lead	
Europe	230V	European Schuko round 2 pin to IEC lead	
USA, Canada and South America	115V	3 flat pin to IEC lead	
Australia & New Zealand	230V	Australasian 3 flat pin to IEC lead	

Connect the equipment in accordance with the connection details and before applying power to the unit, check that the machine has the correct operating voltage for your mains power supply.

**Important Note:** If there is an earth/ground terminal on the rear panel of the product then it must be earthed/grounded.

### WEEE Directive



The Waste Electrical and Electronic Equipment (WEEE) Directive was agreed on 13 February 2003, along with the related Directive 2002/95/EC on Restrictions of the use of certain Hazardous Substances in electrical and electronic equipment (RoHS). The Waste Electrical and Electronic Equipment Directive (WEEE) aims to minimise the impacts of electrical and electronic equipment on the environment during their life times and when they become waste. All products manufactured by Sonifex Ltd have the WEEE directive label placed on the case. Sonifex Ltd will be happy to give you information about local organisations that can reprocess the product when it reaches its “end of use”, or alternatively all products that have reached “end of use” can be returned to Sonifex and will be reprocessed correctly free of charge.

### RoHS Directive



The RoHS directive limits the use of certain hazardous substances currently used in EEE manufacture, including lead, mercury, cadmium, hexavalent chromium, and halide-containing compounds PBB (polybrominated biphenyl) and PBDE (polybrominated diphenyl ether). Elimination of these substances will result in more environmentally friendly recycling of electronic equipment.

Sonifex Ltd practices lead-free (LF) manufacturing processes and does not use any of the hazardous substances identified in the European Union’s Restriction of Hazardous Substances (RoHS) directive. The manufacturing

processes include the assembly of purchased components from various sources. Product is offered as RoHS compliant, or LF, only after sufficient evidence is received from the component manufacturers that their components are RoHS compliant. Sonifex Ltd relies solely on the distributor, or manufacturer, of the components for identification of RoHS compliance. Thus whilst every effort is made to ensure compliance, Sonifex Ltd makes no warranty, or certification, or declaration of compliance concerning said components.

### Atmosphere

The units should be installed in an area that is not subject to excessive temperature variation (<0°C, >50°C), moisture, dust or vibration.

### Fitting Redboxes

Redboxes can be fixed to the underside of a mixing desk, or other surfaces using 4.2mm holes in the sides and fixed with 2 x M4 screws or 2 x No. 6 countersink wood screws.

They can also be rack-mounted, with either the front, or rear of the Redbox positioned at the front of the rack:

Rear Mounting a 1U Rackmount Redbox:

The RB-RK3 1U rear panel rack kit can be used for large 1U rackmount Redboxes.



**Note:** When fitting the RB-RK3 rear-mounting rack-kits, a notch has been left on the inside of the right-hand rack-piece for the mains cable to pass through. Make sure that the mains cable has been put through the notch before attaching the right hand rack-piece.

# Introduction



Fig 1-1: The RB-AEC Acoustic Echo Canceller

## Category

Synchronisers, Delays & Silence Detectors.

## Product Function

Remove acoustic echo in a presenter's earpiece caused by microphones picking up audio from loudspeakers in delay.

## Typical Applications

In a TV production environment where presenters are fed a signal which has some form of acoustic delay or echo. Any situation where adaptive echo cancellation is required.

## Features

The RB-AEC 1U rack-mount is an acoustic echo canceller primarily designed for the benefit of studio personnel for television and radio. When a studio presenter's microphone signal is played out through a monitor speaker in the control room, it can be picked up by the control room microphone(s) and returned to the presenter's earpiece as an undesirable echo.

In circumstances where green screen video processing is taking place, the delay can be greater than 200ms. Additionally, the dimensions, occupancy and distance between mouth and microphone can further influence the echo. The RB-AEC is used to remove the entire control room monitor speaker output from the presenter's feed by adapting to the environment

in which the control room microphones are placed. Although acoustic echo cancellation is more commonly implemented in telephony systems, the Sonifex RB-AEC is designed to produce broadcast quality cancellation.

Much like during a conference call configuration between two rooms, each room has a microphone and speaker to conduct a conversation. When an occupant of one room speaks, it takes a certain length of time before it is received in the second room. Without a suitable solution this 'delayed' signal can then be captured by the microphone in the second room and returned back to the first room as an echo.

In the particular example of TV production, as well as the processing/transmission delay, sound reflections from the control room monitor speaker into the control room microphone(s) cause the studio earpiece to suffer further delay. The sound reflections in the control room vary with the contents of the room including any personnel present. Also, different frequencies produce varying reflections across various types of surfaces and magnitudes within the room. For a 15m distance between speaker and microphone the delay is as much as 40ms. The DSP solution offered by the RB-AEC can dynamically compensate for varying configurations.

## Operation of the RB-AEC

The post-processed transmission output program from the studio (A) is sent to the RB-AEC as an analogue or digital audio signal (the stereo input is auto-sensing) which acts as a mix-minus to the input signal (B) from the Control Room. The RB-AEC removes the unwanted acoustic echoes so that the audio sent to the presenter's earpiece (C) is free of echoes and reflection artifacts.

The RB-AEC is a high performance, reliable single channel acoustic echo canceller designed to be a transparent addition to an existing studio environment.

The canceller will auto-detect analogue and digital inputs with sample rates up to 192kHz. Digital output is available when using a digital input and its sample rate is set to the rate detected at the input.

The settings for the RB-AEC are adjusted using the onboard webserver interface.

## System Block Diagram

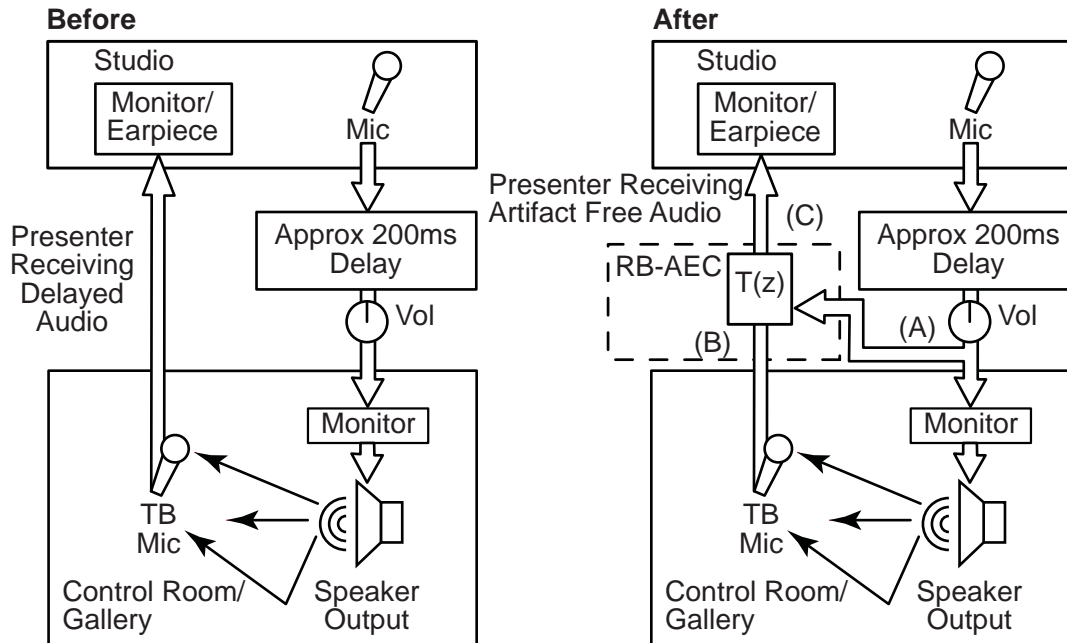

Fig 1-2: The RB-AEC Operational Block Diagram

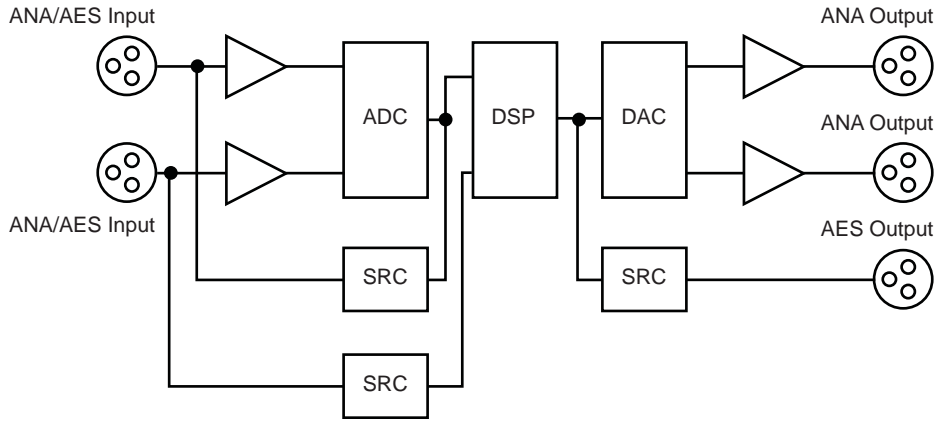

Fig 1-3: The RB-AEC Functional Block Diagram

## Front Panel Controls and Indicators



Power LED  
Reset Button

Fig 2-1: The RB-AEC Front Panel

### Power LED

The POWER LED illuminates whilst internal power is present within the unit. If this indicator is not on, the most likely reason is simply the absence of mains power, but under fault conditions it may also indicate a ruptured mains fuse or a problem with the internal power supply module.

### Reset Button

In the unlikely event that the unit fails to respond, press and hold the reset button for 3 seconds to reboot the unit

## Rear Panel Connections and Controls

### Inputs

#### Far End Input

An XLR 3 pin socket is used for the FAR END input channel and it can take an analogue or AES/EBU digital feed. The input will automatically detect whether the source is analogue or digital. It is electronically balanced, with the following connections:

- Pin 1: Screen.
- Pin 2: Phase.
- Pin 3: Non-phase.

The source of this XLR input must be from the audio feed that is the source of the echo. This is used by the cancelling algorithm to calculate what to remove from the near end.

#### Near End Input

An XLR 3 pin socket is used for the NEAR END input channel and it can take an analogue or AES/EBU digital feed. The input will automatically detect whether the source is analogue or digital. It is electronically balanced, with the following connections:

- Pin 1: Screen.
- Pin 2: Phase.
- Pin 3: Non-phase.

The source of this XLR input must be from the audio feed that is contaminated with the echo. It is from this feed, that the cancelling algorithm will be subtracting it's echo estimation to produce an echo free result.

### Outputs

#### Analogue Outputs 1 & 2

The analogue outputs consist of two XLR male connectors professionally balanced with following connections:

- Pin 1: Screen.
- Pin 2: Phase.
- Pin 3: Non-phase.



Fig 2-2: The RB-AEC Rear Panel

Both channels contain the same signal. When using analogue as the input type, only analogue outputs are enabled.

### Digital Output

The digital output is connected using a male XLR connector on the rear panel. This XLR 3 pin plug has an impedance of 110Ω with the following connections:

- Pin 1: Screen.
- Pin 2: Phase.
- Pin 3: Non-phase.

When using analogue as the input type, this output is disabled.

### General Note About Inputs & Outputs

The analogue and digital outputs will both be present when digital inputs are used. The digital output is disabled when an analogue input is used because it detects the clock from the digital input to detect the input/output sample rate. However, it is possible to use different analogue and digital input configurations for the Near End and Far End inputs.

### Settings DIPSwitch

Unit Settings are configured using a 4 way DIPSwitch:

Settings DIPSwitch	
1	Far end digital input termination. ON = Terminated, OFF = Unterminated
2	Near end digital input termination. ON = Terminated, OFF = Unterminated
3	ON = Bootstrap mode, OFF = Normal mode
4	ON = Disable cancellation (Bypass), OFF = Enable cancellation

### Input Termination

110Ω input termination for the AES/EBU digital inputs are controlled by the settings of DIPSwitches 1 and 2, as follows:

- SW1:** When set to ON, Far end digital input is terminated with 110Ω.
- SW2:** When set to ON, Near end digital input is terminated with 110Ω.

### Bootstrap Mode

To enable bootstrap mode, power the unit off, switch DIPSwitch 3 to ON and power up the unit. The RB-AEC can now be programmed with new firmware.

**Warning:** This removes the main firmware from the unit and should not be necessary unless the unit has been loaded with incorrect or corrupt

firmware. Once in Bootstrap Mode you will need to load main firmware into the device using a standalone application. Contact Sonifex for more information.

### ***Bypass Cancellation***

To test whether the product is effective in your application, you can configure it and then toggle DIPSwitch 4 to listen to the effect with (OFF) and bypassed without (ON) cancellation.

### **GPIO Connector**

This is a 9 way D-type socket with the following connection details:

GPIO Pin			
Pin No	Signal	I/O	Description
Pin 1	GPO1	O	General purpose output 1 - Power good
Pin 2	GPO2	O	General purpose output 2
Pin 3	GPO3	O	General purpose output 3
Pin 4	GPI1	I	General purpose input 1 - Mute input detect
Pin 5	GPI2	I	General purpose input 2
Pin 6	GPI3	I	General purpose input 3
Pin 7	12VDC	-	50mA fused +12V power supply
Pin 8	DGND	-	Ground return for external circuits
Pin 9	DGND	-	Ground return for external circuits

### ***Power Good***

Pin 1 shows a power fail condition. This open collector output is normally HIGH. Should a power failure occur, this level will go low (DGND).

### ***Mute Input Detect***

Setting the mute input detect pin 4 to DGND 0V will disable adaption. This may prevent the canceller from becoming unstable when the input is muted.

### **Ethernet Port**

The Ethernet port is connected using a standard RJ-45 connector on the rear of the panel. It is a 10/100Mbps link. The unit can be controlled remotely over the Ethernet connection using the built-in webserver. By default the unit is configured for dynamic addressing using DHCP and Auto-IP. If a static IP address is required then this must be configured through the webserver.

The connections for the RJ45 connector are as follows:

Ethernet Connector (RJ-45)	
Pin No.	Function
Pin 1	Transmit data (+)
Pin 2	Transmit data (-)
Pin 3	Receive data (+)
Pin 4	No connection
Pin 5	No connection
Pin 6	Receive data (-)
Pin 7	No connection
Pin 8	No connection

### **Mains Power**

Power is applied via a standard three-pin IEC male socket. Mains voltages between 85V and 264V AC and frequencies between 47 and 63Hz are accepted without adjustment.

A 2A, 5 x 20mm SB fuse is used. The Earth pin MUST be connected to ensure safety.



## Applications

### How to Remove Delayed Presenter's Audio From Their Earpiece

#### The Problem:

Microphone audio from the presenter(s) is played aloud in the control room/gallery, where a live microphone allows the director to talk to the presenter(s) via their earpiece(s). This live microphone also inadvertently picks up the presenter's microphone audio and feeds it back to them in delay, causing a disconcerting self-echo in their earpiece.

#### The Solution:

1. Connect the director's microphone signal (at line level) to the RB-AEC near-end input.
2. Connect the gallery monitor signal (at line level, containing the presenter's microphone audio) to the RB-AEC far-end input.
3. Connect the RB-AEC output(s) to the presenter's earpiece(s). Turn on the RB-AEC.
4. Allow the presenter(s) to talk for 1 minute without the director using their microphone (though it must still be active). The RB-AEC will learn the environment and the echo will gradually disappear from the presenter's earpiece(s). The coefficients are stored and loaded on power-up. This process will not need repeating unless the environment changes.

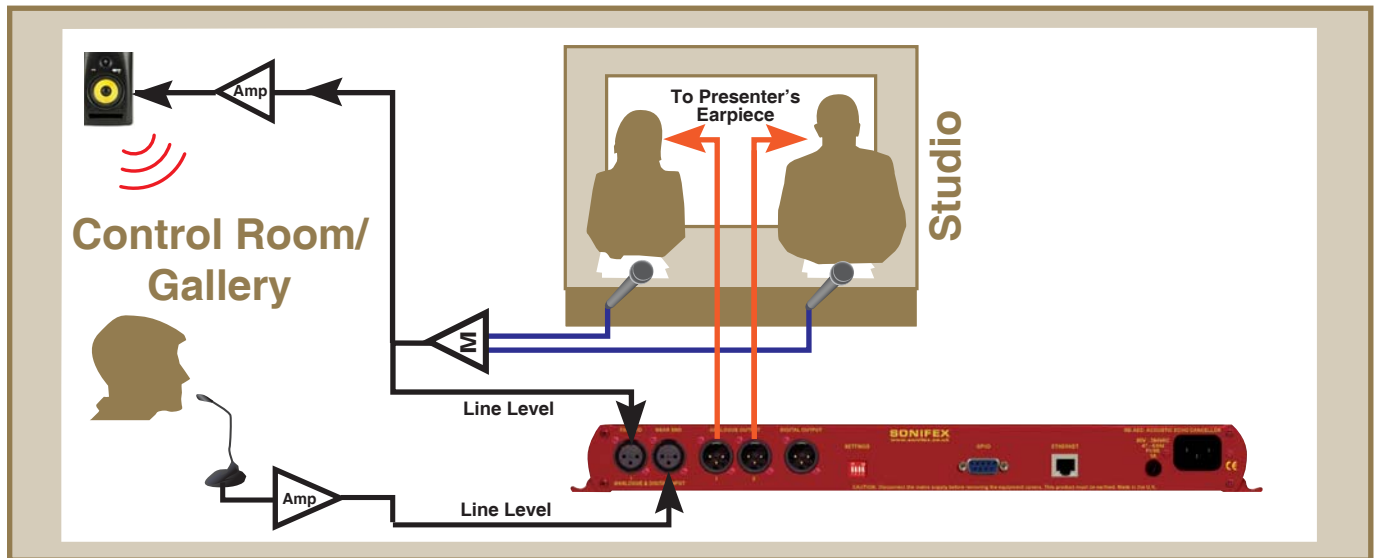

## How to Remove Delayed Caller Audio From The Telephone Line

### The Problem:

Caller audio from the telephone hybrid is played aloud in the TV studio, where live microphones are fitted to presenters and guests (boundary microphones may also be present). These live microphones also inadvertently pick up the caller's audio and feed it back to them in delay, causing an undesirable self-echo.

### The Solution:

1. Connect the mixed studio microphones signal (at line level) to the RB-AEC near-end input.
2. Connect the TBU output to the RB-AEC far-end input.
3. Connect the RB-AEC output(s) to the hybrid's input (in line mode). Turn on the RB-AEC.
4. Make a test call and allow the caller to talk for 1 minute, their voice played aloud through the studio monitor and being picked up by all studio microphones (which should be in-position and active but not being used). The RB-AEC will learn the environment and the echo will gradually disappear from the phone line. The coefficients are stored and loaded on power-up. This process will not need repeating unless the environment changes.

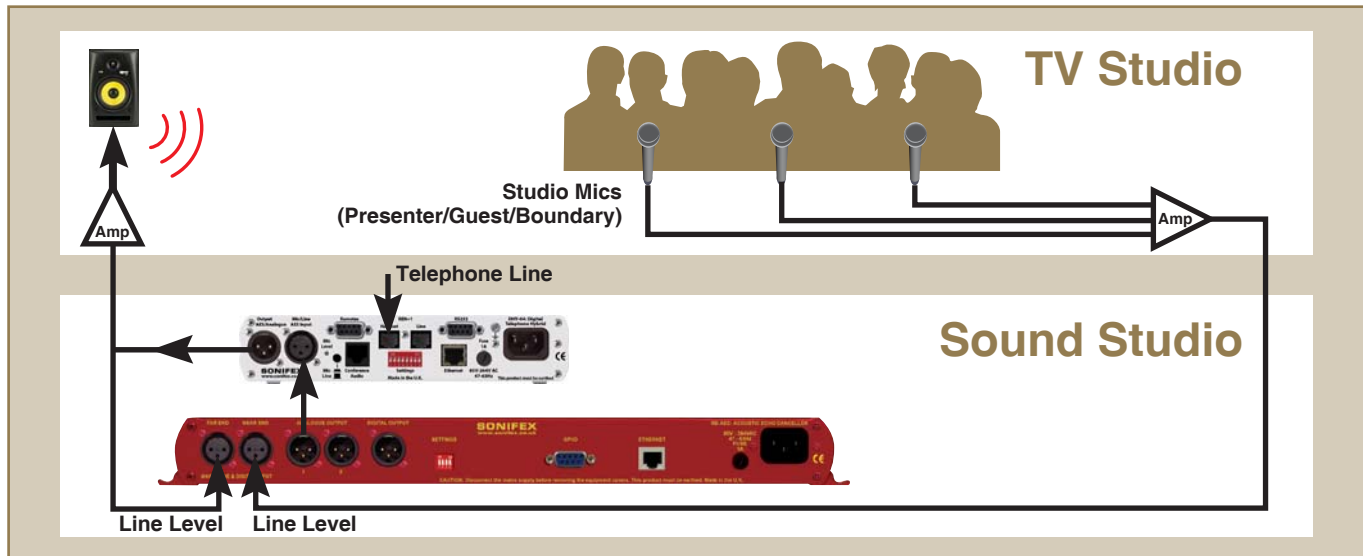

## Calibration

When using the RB-AEC for the first time, the unit must first be calibrated to suit the environment in which it will be used. Using the webserver, select the 'Config' tab.

1. Select the desired sample rate.
2. Measure the distance between the speaker and microphone in centimetres. Halve this number and enter it here. Example: For a distance of 100cm, enter 50. Otherwise leave this value at zero.
3. Tick the box labelled 'Load Saved Coefficients on Startup'. This will ensure that any saved coefficients are used next time the unit is switched on.
4. Set the presenter's (Far End) silence detect threshold. Levels below this value will disable the canceller.
5. You also have the option of enabling the noise gate, setting the threshold and changing the release time.
6. Submit your settings
7. For calibration, ensure the control room is silent and speak into the presenter's microphone while monitoring using the presenter's earpiece for around one minute or until the echo has subsided to a satisfactory level.
8. Save your coefficient values so they can be used as a starting point for next time the RB-AEC is used.

## Webserver & Unit Discovery

The RB-AEC uses the Zeroconf networking methodology to allow the unit to be a “plug and play” device. Just simply connect it to the network and use it. The unit is assigned an IP address using a DHCP server, or a self-assigned address using AUTOIP when one isn’t available. The RB-AEC can also use Bonjour discovery on a network.

Once the RB-AEC has been connected to the network, it will try to obtain an IP address from a DHCP server on the network. If none is found then the unit will use Auto-IP to assign itself an IP address.

There is no direct method for you to determine exactly which IP address has been assigned to the unit. However, using a Bonjour discovery application or browser plug-in, the unit can be discovered and connected to with relative ease.

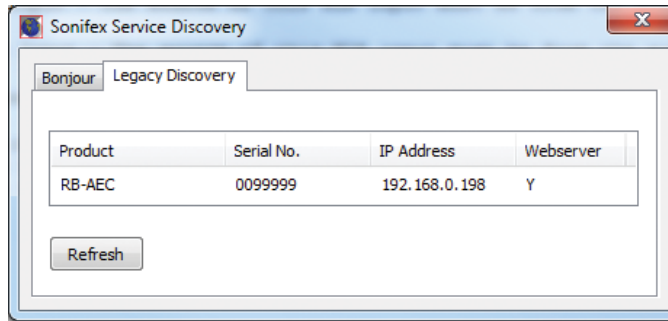

Fig 4-1: The RB-AEC Sonifex Service Discovery Tool

The Sonifex device can be detected using the Sonifex Discovery Tool and the device’s webserver may be launched.

Bonjour is available as standard on MAC OS and as plug-in for Internet Explorer for the ‘Bonjour for Windows’ download. You can also use the discovery application provided by Sonifex and available for download on the Sonifex website [www.sonifex.co.uk](http://www.sonifex.co.uk)

### Running The Webservice

Use Google Chrome or Mozilla Firefox browsers and simply type in the RB-AEC IP address.

## Home Page

The input type for both far end and near inputs is shown. Without an AES/EBU digital lock detected, the input type will be shown as 'Analogue'. When the unit has detected digital lock, the 'Digital' input type will be displayed.

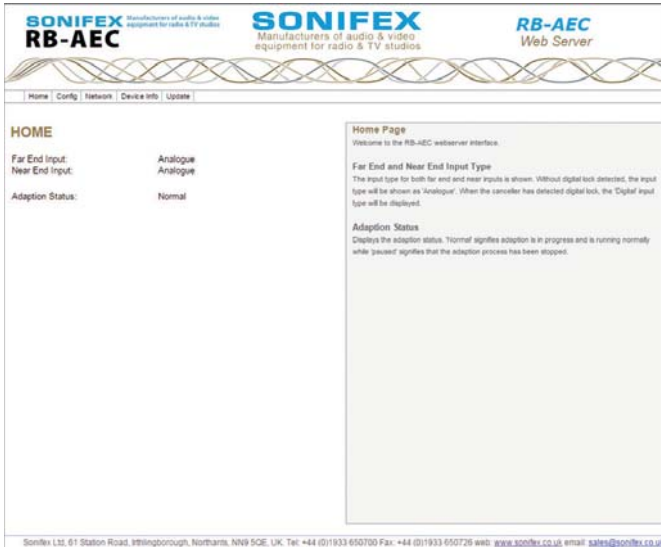

Fig 4-2: The RB-AEC Webserver Interface - Home

Welcome to the RB-AEC1 webserver interface.

The input type for both far end and near inputs is shown. Without digital lock detected, the input type will be shown as 'Analogue'. When the canceller has detected digital lock, the 'Digital' input type will be displayed.

## Far End and Near End Input Type

The input type for both far end and near inputs is shown. Without digital lock detected, the input type will be shown as 'Analogue'. When the canceller has detected digital lock, the 'Digital' input type will be displayed.

## Adaption Status

Displays the adaption status. 'Normal' signifies adaption is in progress and is running normally while 'paused' signifies that the adaption process has been stopped.

## Configuration Page

This page shows the configuration options for the RB-AEC.

Fig 4-3: The RB-AEC Webserver Interface - Configuration

### Sample Rate

Select the required processing sample rate from the drop down menu. When analogue inputs are used, the canceller will sample at either 16 or 24kHz. The canceller accepts digital input sample rates between 32 - 192kHz. The canceller will convert the sample rate based on the user's choice to either 16kHz or 24kHz for processing. This will then be returned to its original sample rate after processing. When the sample rate is changed, the canceller will need to recalculate the coefficient values from zero.

### Offset

Measure the distance between the speaker and microphone in centimetres. Halve this number and enter it here. Otherwise leave this value at zero. Example: For a distance of 100cm, enter 50.

### Reset Coefficients

If the canceller is performing poorly it may be necessary to reset the coefficient values and allow the AEC to recalculate. Click to clear all current coefficient values.

### Save Coefficients

When a working configuration is found, the coefficients can be saved to flash so that the next time the system is used a working configuration can be easily loaded. Click to save all current coefficient values.

### Load Saved Coefficients Now

If you have saved coefficients from a previous setup, tick the box to load the saved coefficients from flash.

### Load Saved Coefficients on Startup

If you have saved coefficients from a previous setup, tick the box to load the saved coefficients from flash at startup.

### Far End Silence Detect Threshold:

This value sets the threshold at which the adaption process is paused during periods where no-one is speaking at the far end. Select a threshold from the drop down list. -6dBFS will set the threshold to half of the maximum value, while 'No Threshold' will allow the adaption to continue all the time.

### Enable Noise Gate:

When enabled, the noise gate will lower the output level based on the threshold set below.

**Noise Gate Threshold:**

This threshold sets the point at which the noise gate is enabled or disabled.

**Noise Gate Release Time:**

After the noise gate has been triggered, a length of time can be set before the gate can be released. This helps prevent the gate from being activated during speech. Set a time in milliseconds between 0 and 500.

**Network Page**

Displays the Hostname, Static IP Address, Static subnet mask, Gateway IP address, and whether DHCP and Auto IP are enabled.



Fig 4-4: The RB-AEC Webserver Interface - Network

**Network Settings**

**Host Name**

Enter the host name used by Bonjour. The Host name can be up to 63 alphanumeric characters in length, and can include hyphens (-). If a conflict occurs on the network this value may be overwritten.

### Static IP Address

Enter the static IP address that you wish to assign to this unit. This IP address will be used if Dynamic addressing is disabled.

The default static IP address is 192.168.0.100

### Static Subnet Mask

Enter the subnet mask of the network you wish to connect to.

The default subnet mask is 255.255.255.0

### Gateway IP Address

Enter the gateway IP address of your router.

The default gateway is 192.168.0.1

### Dynamic Addressing

Enable dynamic addressing to allow the unit to acquire it's IP address automatically from a DHCP server or using AUTOIP. Disable dynamic addressing to use the static IP address entered on this page.

To transfer the new network settings to the connected RB-AEC, press the Submit button. This may require a restart by Internet Explorer

## Device Info Page

This page shows general information about the connected RB-AEC.

The screenshot shows the RB-AEC Webserver interface. At the top, there are logos for SONIFEX RB-AEC and RB-AEC Web Server. Below the logos is a navigation menu with links: Home, Config, Network, Device Info, Update. The main content area is divided into two sections: DEVICE INFO and NETWORK INFO. The DEVICE INFO section lists: Device: RB-AEC, Serial Number: 0, Description: Sonifex RB-AEC, Bonjour Name: RB-AEC-0, Firmware Version: v1.01.066.167, Base Version: V1.0.15, Config Set: RB-AEC default setup, System Up Time: 00h:44m:14s. The NETWORK INFO section lists: Connectivity: Dynamic D - 100Mbps, Actual IP Address: 192.168.0.224, Actual Subnet Mask: 255.255.255.0, Actual Gateway IP: 192.168.0.149, Hardware Address: 00:50:C2:05:AB:F1. On the right side, there is a 'Device Info' box with the text: 'This page shows general information about the connected RB-AEC.' At the bottom of the page, there is a footer with contact information: Sonifex Ltd, 61 Station Road, Hittingborough, Northants, NN19 5QE, UK. Tel: +44 (0)1933 650700 Fax: +44 (0)1933 650726 web: www.sonifex.co.uk email: sales@sonifex.co.uk

Fig 4-5: The RB-AEC Webserver Interface - Device Info



## Update Page

To update the RB-AEC firmware, download the latest file from the Sonifex website, select Choose File to find it and click Update to load it into the RB-AEC.



Fig 4-6: The RB-AEC Webserver Interface - Update

## Update

The version of firmware currently running on this unit is V1.0.6.

To find out if there is new firmware for this unit, check the Sonifex website. If an update is available, download the latest version and save the file to your computer. Browse your computer to locate and select the file, and press the update button. Once the update has started, this page will update

automatically.

The file must be named according to the following convention "RB-AEC" followed by any version or other info then a ".DWN" suffix - e.g "RB-AEC v1\_02 special release.dwn"

## Technical Specification For RB-AEC

### Audio Specification

Audio Input (Near End/Program):	1 x mono analogue or AES/EBU digital on XLR 3-pin female (autoselecting)
Audio Input (Far End/ From Control Room):	1 x mono analogue or AES/EBU digital on XLR 3-pin female (autoselecting)
Max Level (0dB Input Gain):	+18dBu (analogue) 0dBFS (digital)
CMRR:	>60dB typical
Input Impedance:	20k $\Omega$ (analogue) 110 $\Omega$ (digital with termination switchable)
AES/EBU Input:	32kHz to 192kHz
Audio Outputs (Analogue):	2 x mono analogue on XLR 3-pin male
Audio Outputs (AES/EBU):	1 x stereo digital AES/EBU on XLR 3-pin male
Maximum Output Level:	+18dBu (analogue)/ 0dBFS (digital)
Output Impedance:	<50 $\Omega$ (analogue)/110 $\Omega$ (digital)
AES/EBU Output Sample Rates:	Selectable 32kHz - 192kHz
Distortion:	fs = 16kHz, THD+N<0.01%, 8dBu, 20Hz-8kHz, unity gain, 8kHz BW fs = 24kHz, THD+N<0.01%, 8dBu, 20Hz-12kHz, unity gain, 12kHz BW
Noise:	-84dB RMS, unity gain ref +8dBu output
Frequency Response:	20Hz-9.5kHz +0/-0.5dB
Rejection Ratio (Input to Output):	Typically 35dB on complex waveforms, reference peak level of 0dB

Remote I/O Port:	9 way D-type socket
Ethernet Port:	1 x RJ45 with status LEDs
Mains Input:	Filtered IEC, continuously rated 85 264VAC @ 47-63Hz, 10W max
Fuse Rating:	Anti-surge fuse 1A 20 x 5mm

### Controls

Configuration:	1 x Ethernet port, webserver 1 x rear panel 4-way DIPSwitch
Reset:	1 x front panel recessed button

### Equipment Type

RB-AEC:	Acoustic echo canceller
---------	-------------------------

### Physical Specification

Dimensions (Raw):	48cm (W) x 10.8cm (D) x 4.2cm (H)(1U) 19" (W) x 4.3" (D) x 1.7" (H) (1U)
Dimensions (Boxed):	58.5cm (W) x 22.5cm (D) x 7cm (H) 23" (W) x 8.9" (D) x 2.8" (H)
Weight:	Nett: 1.5kg Gross: 2.0kg Nett: 3.3lbs Gross: 4.4lbs



**SONIFEX**

[www.sonifex.co.uk](http://www.sonifex.co.uk)

t:+44 (0)1933 650 700

f:+44 (0)1933 650 726

[sales@sonifex.co.uk](mailto:sales@sonifex.co.uk)