

SONIFEX

Reference Monitors

2014-15
Catalogue





Reference Monitor Rackmount Audio Monitors

The three monitors in the range are:

RM-2S4 Reference Monitor, 2 LED meters, 4 stereo channel audio inputs.

RM-2S10 Reference Monitor, 2 LED meters, 10 stereo channel audio inputs.

RM-4C8 Reference Monitor, 4 LED meters, 8 channel inputs, dual selectors.

The Reference Monitor Range is a series of rack-mount audio monitors, combining the latest DSP technology with outstanding audio enclosure design to produce monitors of the highest standards with exceptional sound quality, a comprehensive feature set and good looks in the rack.

Uniquely an embedded 5 band parametric EQ allows you to configure the monitor for your environment or to suit your listening tastes.

Detail In The Design

In the design of the product, every care has been taken to ensure the best and most accurate reproduction of the audio sources.

In a 1U rack, the propagation of high power sound waves in such a small enclosure could have a tendency to produce rattles or move components, but the Reference Monitors

have been designed to ensure that their audio performance is not compromised.

Anti-Vibration

A welded and sealed stainless-steel case with milled aluminium fascia provides exceptional rigidity and has been used to ensure that there are no extraneous metallic rattles. The lid is sealed with extensive thin foam cut-outs to provide damping to the lid and multi-point screw fixings are used to ensure lid rigidity.

The XLR and USB port connectors on the rear panel are sealed with foam, and silicon sealant is used on components which could move, or vibrate, under high SPL conditions.

Accurate Sound System

The speaker system comprises a three-way arrangement with two mid/high frequency speakers providing excellent stereo imaging and a separately driven, forward facing, dual magnet, mono bass driver.

Custom-moulded, profiled, HF enclosures are used to minimise standing waves and eliminate response peaks, and acoustic damping in the HF enclosures is used to reduce colouration, effectively creating a separate, sealed, infinite-baffle enclosure for each driver.

Each speaker uses a separate, highly efficient class-D switching amplifier.

Even cable lengths to and from the speaker enclosures have been kept short to reduce any potential microphonic induction.

Audio Modifiers

Six illuminated soft-touch pushbuttons allow front panel muting and dimming of the loudspeakers, stereo-to-mono conversion, phase inversion and Middle+Side encoding/decoding with all front panel settings stored in non-volatile memory which is recalled at power-up. A universal power supply ensures global voltage operation without adjustment.



Six illuminated soft-touch pushbuttons.

DSP Based Design

The use of a modern electronic architecture allows a much better audio performance to be realised. The DSP-based, 3rd-order active crossover provides perfect separation between mid-range and bass sounds.

A DSP-based electronic equalisation is used to flatten the frequency response and also enables the 5 band parametric EQ. Additionally, the fast-attack DSP loudspeaker limiter protects the drivers from overload damage.

Optional HD Expansion Cards

A number of plug-in expansion cards are available allowing multiple AES groups embedded within an HD-SDI or SD-SDI signal to be de-embedded and monitored, or allowing Dolby® E or Dolby® Digital encoded signals to be monitored directly:

- RM-HD1** HD-SDI expansion card
- RM-HDE1** HD-SDI & Dolby® E expansion card
- RM-E1X** Dolby® E expansion card, XLR
- RM-E1B** Dolby® E expansion card, BNC.

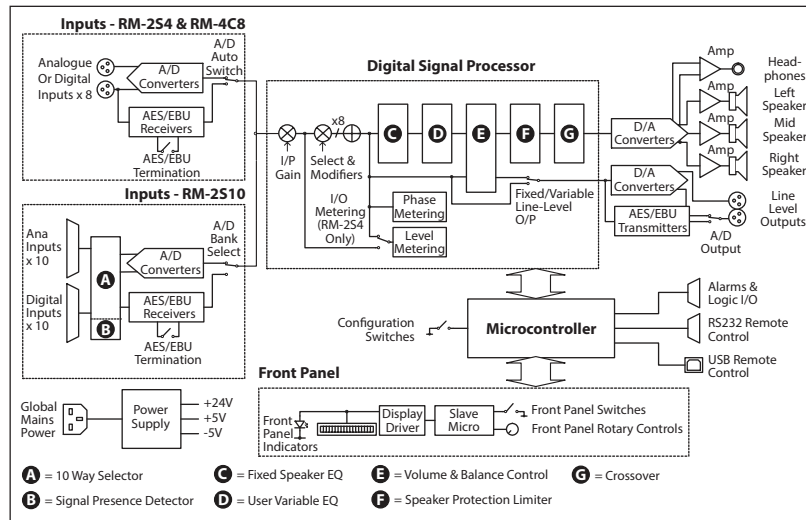

Reference Monitor Block Diagram.

5 Band Parametric Equalisation

Each product in the Reference Monitor range contains an embedded 5 band parametric equaliser.

The Reference Monitor products are often installed in OB trucks or engineering rooms where the acoustics aren't ideal. The addition of a 5 band parametric EQ allows you to alter the sound of your

monitor to account for the acoustic conditions, or to suit your particular listening tastes.

Using the free of charge Sci remote control software, preset EQ settings can be selected, or different EQ settings can be created and stored.

Available Scales/Ballistics For Reference Monitors

There are nine scales available with accurately modelled ballistics. Each stereo meter pair can have a different scale, set via a DIPswitch on the underside.

A complete set of overlays are provided per stereo meter so that you can define the scale(s) that you need:

1. Dual BBC PPM + standard VU
2. BBC PPM IEC60268-10 11a
3. EBU PPM IEC60268-10 11b
4. Nordic PPM IEC60268-10 1
5. AES/EBU digital PPM IEC60268-18
6. DIN PPM DIN45406
7. Standard VU IEC60268-17
8. Extended VU IEC60268-17
9. German PPM



RM-2S4 Reference Monitor, 2 LED Meters & 4 Stereo Inputs



Category: Reference Monitors

Product Function: Audible and visual metering of audio sources.

Typical Applications: Monitoring of multiple audio sources in an OB truck or engineering racks room.

Features: 3 speaker system, 5 band parametric EQ, phase meter, audio modifiers, multiple scales, analogue and digital inputs, superb sound, option for HD/SD-SDI de-embedding.

The RM-2S4 is a 1U rackmount unit offering quality loudspeaker monitoring and accurate, high-resolution metering of up to four stereo audio sources and more with the addition of optional expansion cards. Sources may be in any mixture of analogue and AES/EBU digital formats, with sample rates up to 192kHz accepted.

Audio inputs can be analogue or digital because they are autoswitching using the left Neutrik™ XLR for AES/EBU, or both Neutrik™ XLRs for analogue inputs and they can be used in any combination.

Analogue inputs can be balanced or unbalanced. The digital inputs have switchable AES/EBU termination for (close-range) bridging operation and there is extra global input gain available for both analogue and digital low-level sources.

Sources (and additional banks of sources, if fitted) are selected via a front panel rotary encoder, with clear LED indication of the current selection.

A pair of line level audio outputs, configurable as analogue or AES/EBU digital, follow the selected source at either a fixed level or one mirroring the loudspeaker volume.

The level of the chosen source is displayed on a pair of bright, multicoloured 53-segment bargraph meters, with a number of accurately modelled scales/responses to suit different applications and local preferences. Clear scale labels are provided for you to choose the scale displayed and the meter brightness can be adjusted from the front panel. A separate phase meter indicates channel correlation or phase

error conditions. On the rear panel, open-collector alarm outputs provide hardware indication of sustained underlevel, overlevel, phase errors and digital source lock.

Six illuminated pushbuttons provide access to a range of audio 'modifiers' – instant dimming of the volume, individual muting of each audio channel, stereo-to-mono conversion, phase inversion and Middle+Side transcoding. On the rear panel, logic-level inputs allow direct remote access to the DIM and MUTE functions.

The three-way loudspeaker system is fed via a DSP-based active crossover and a trio of highly efficient Class-D amplifiers. Careful attention to driver selection, materials and case design, plus active DSP equalisation, has ensured a flat response and outstanding reproduction from such a

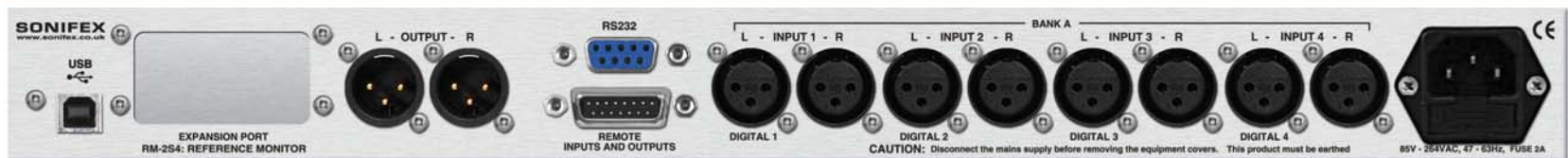



The RM-2S4 and RM-2S10 are both monitor bridges which accept stereo audio sources and have the same high specifications.

shallow unit. A protective limiter prevents damage to the loudspeakers under overload conditions and the front-panel headphone socket automatically mutes the internal loudspeakers when a plug is inserted.

A balance control allows you to alter the stereo imaging of the left and right channels.

A further five-band parametric equaliser can be accessed for room-equalisation purposes via Sonifex SCi Windows-based remote control software. Source selection, status monitoring and unit ID functions, plus firmware updates to add extra functionality,

are all accessible remotely via both USB and RS232 connections. The open control protocol also allows operation with terminal programs or customised applications.

An RM-HD1 HD/SD-SDI input expansion card can be added, allowing multiple AES groups embedded within an HD-SDI or SD-SDI signal to be de-embedded and monitored.

The RM-2S4 operates from global mains voltages (85-264V AC, 47-63Hz).

RM-2S10 Reference Monitor, 2 LED Meters, 10 Stereo Analogue & 10 Stereo Digital Inputs

The RM-2S10 has the same extended feature set of the RM-2S4, monitoring stereo channels, but has 10 dedicated stereo analogue and 10 dedicated stereo AES/EBU digital audio sources, with sample rates up to 192kHz accepted.

The RM-2S10 uses 25 way D-type connectors for the audio inputs on the rear panel instead of Neutrik™ XLR connectors.

Sources are still selected via a front panel rotary encoder, but on the RM-2S10 the Source LEDs also act as signal present indicators.

In all other aspects the units have the same feature set.

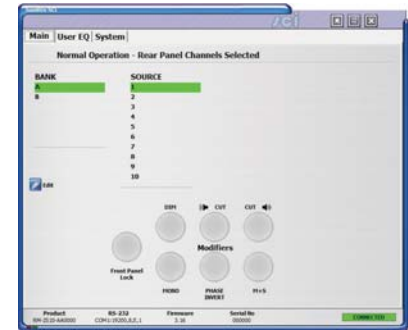

SCi Software Screen for RM-2S10.



Technical Specification For RM-2S4 & RM-2S10

Inputs	
Audio Inputs (RM-2S4):	4 x stereo analogue or AES/EBU digital (autoselecting)
Audio Inputs (RM-2S10):	10 x stereo analogue, plus 10 x stereo AES/EBU digital
Max Level (0dB Input gain):	+18dBu (analogue)/0dBFS (digital)
CMRR:	>60dB typical
Input Impedance:	20kΩ (analogue) 110Ω (digital with termination switchable)
AES/EBU Sample Rate:	32 to 192kHz, converted internally to 48kHz
Input Gain:	0, +6, +12 or +18dB digital gain (switchable)
Selection:	Front panel rotary control with indicator LEDs
Line Level Outputs	
Audio Outputs:	1 x stereo analogue or AES/EBU digital (switchable)
Gain re Selected Input:	Unity or variable, following volume control (switchable)
Maximum Output Level:	+18dBu (analogue)/0dBFS (digital)
Output Impedance:	<50Ω (analogue)/110Ω (digital)
AES/EBU Sample Rate:	48kHz
Distortion:	<0.02% (1kHz, +8dBu output)
Noise:	-84dB RMS, unity gain ref +8dBu output
Frequency Response:	20Hz-20kHz +0/-0.5dB
Crosstalk	Analogue I/O, ref 0dBu
1kHz input:	<-90dB
10kHz input:	<-85dB
Audio Modifiers	
Modifier Selection:	Illuminated front panel pushbuttons

DIM:	Reduces speaker audio level by 10dB
CUT L & CUT R:	Mutes left/right speaker audio
MONO:	Combines left and right audio inputs
PHASE INVERT:	Inverts phase of right audio input
M+S:	Converts stereo input to Middle (sum) and Side (difference) signals
User-Variable Equalisation	
Type:	Parametric
Bands:	Five
Centre Frequency:	200Hz to 18kHz
Bandwidth:	0.25 to 2 octaves
Boost/Cut:	±12dB
Programming:	Via USB/serial control port
Amplifier/Loudspeakers	
Configuration:	Three-way with stereo mid/high-frequency drivers & mono low-frequency driver
Power Output:	2 x 5W (HF) + 20W (LF) with protective limiter
Crossover:	500Hz (3rd order Butterworth)
Distortion (HF Outputs):	< 0.05% (1kHz, 3W output)
Distortion (LF Output):	< 0.05% (100Hz, 6W output)
Noise:	More than 80dB below full output
Volume:	Mute to full volume via front panel rotary control
Balance Trim:	±6dB via front panel rotary control.
Peak Acoustic Level:	102dB SPL @ 2ft
Level Metering	
Number:	2 x 53-segment tri-colour LED bargraphs

Characteristics:	Selectable by switch from: 1. Dual BBC PPM + standard VU 2. BBC PPM 3. EBU PPM 4. Nordic PPM 5. AES/EBU digital PPM 6. DIN PPM 7. Standard VU 8. Extended VU 9. German PPM
Ballistics:	According to selected characteristic
Line-Up Level:	According to selected characteristic
Phase Metering	
Type:	5-segment, indication at 0, 45, 90, 135 and 180 degrees
Remote Control	
USB:	Slave device, 19200 baud
Serial:	RS232, 19200 baud, 3-wire connection
Alarm Outputs:	1. Audio underlevel/fail (latching) 2. Audio overlevel (latching) 3. Sustained phase error (latching) 4. AES/EBU input unlock (non-latching) Open-collector outputs rated at 30V, 50mA maximum Output low/conducting in normal condition (no alarm)
Control Inputs:	1. Mute audio 2. Dim audio 3. Alarm reset Pull-to-ground to activate inputs
Status Indicators	
LIMIT:	Indicates loudspeaker protection limiter is active.
CLIP:	Indicates internal digital clipping due to overlevel.
LOCK:	Indicates lock achieved on selected digital input(s).
OPT:	For future use.
Connectors	
Audio Inputs (RM-2S4):	8 x XLR 3-pin female (balanced, may be unbalanced)

Audio Inputs (RM-2S10):	3 x D-type 25-pin female (balanced, may be unbalanced)
Audio Outputs:	2 x XLR 3-pin male (balanced, may be unbalanced)
Headphones:	1/4" (6.35mm) A-gauge 3-pole stereo jack socket
USB:	Type B socket
Serial:	D-sub 9-pin female
Remote I/O:	D-sub 15-pin male
Mains Input:	Filtered 3-pin IEC male, continuously rated 85 - 264VAC, 47 - 63Hz, fused, 60W peak, 30W average
Fuse Rating:	Anti-surge fuse 2A 20 x 5mm
Equipment Type	
RM-2S4:	Reference Monitor, 2 LED meters, 4 stereo channel inputs
RM-2S10:	Reference Monitor, 2 LED meters, 10 stereo channel inputs
Physical Specification	
Dimensions (Raw):	48cm (W) x 30.5cm (D) x 4.4cm (H) (1U) 19" (W) x 12" (D) x 1.73" (H) (1U)
Dimensions (Boxed):	58cm (W) x 52cm (D) x 14cm (H) 22.8" (W) x 20.5" (D) x 5.5" (H)
Weight:	Nett: 4.5kg Gross: 6kg Nett: 10lb Gross: 13.2lb
Options	
RM-HD1:	HD-SDI expansion card



RM-4C8 Reference Monitor, 4 LED Meters, 8 Channel Inputs & Dual Source Selectors



Category: Reference Monitors.

Product Function: Audible and visual metering of audio sources.

Typical Applications: Monitoring of multiple audio sources in an OB truck or engineering racks room.

Features: 3 speaker system, 5 band parametric EQ, phase meter, audio modifiers, multiple scales, analogue and digital inputs, superb sound, options for HD/SD-SDI de-embedding & Dolby® E decoding.

With 4 x bright high-resolution 26-segment meter displays and separate left and right source selectors, the RM-4C8 is ideal for monitoring audio channels in an SDI group, or groups of de-embedded AES/EBU channels.



SCI Software Screen for RM-4C8.

The RM-4C8 offers the same functionality as the RM-2S4 but with an additional source selector so that any of the 4 channels in the selected group, or bank, can be monitored independently on left and right speakers.

Also, 4 meters are provided so that every channel in the selected group, or bank, can be visually monitored. All audio channels in an HD-SDI signal can be monitored using the optional RM-HD1 card and Dolby encoded audio signals can be monitored using the RM-HDE1, RM-E1B or RM-E1X expansion cards.

The audio inputs on the RM-4C8 are auto-sensing, for digital AES/EBU using the left

input XLR, or both XLRs for analogue inputs. The inputs can be used in any combination of analogue or digital.

With full remote control via GPI, RS232 or USB, a 5 band parametric equaliser, 6 front panel modifier buttons and the ability to take the optional HD-SDI expansion cards, the RM-4C8 is a flexible and versatile monitoring solution.

The same high level of care has been taken in the design of the RM-4C8 as in the RM-2S4 to ensure that it's the best sounding 1U rack-mount audio monitor that you'll hear.



Technical Specification For RM-4C8

Audio Specification

Inputs	
Audio Inputs	8 analogue or AES/ EBU digital channels (autoselecting)
Max Level (0dB Input Gain):	+18dBu (analogue)/0dBFS (digital)
CMRR:	>60dB typical
Input Impedance:	20kΩ (analogue) 110Ω (digital with termination switchable)
AES/EBU Sample Rate:	32 to 192kHz, converted internally to 48kHz
Input Gain:	0, +6, +12 or +18dB digital gain (switchable)
Selection:	2 x Front panel rotary controls with indicator LEDs
Line Level Outputs	
Audio Outputs:	1 x stereo analogue or AES/EBU digital (switchable)
Gain re Selected Input:	Unity or variable, following volume control (switchable)
Maximum Output Level:	+18dBu (analogue)/0dBFS (digital)
Output Impedance:	<50Ω (analogue)/110Ω (digital)
AES/EBU Sample Rate:	48kHz
Distortion:	<0.02% (1kHz, +8dBu output)
Noise:	-84dB RMS, unity gain ref +8dBu output
Frequency Response:	20Hz-20kHz +0/-0.5dB
Crosstalk 1kHz input:	Analogue I/O, ref 0dB <-90dB
10kHz input:	<-85dB

Audio Modifiers

Modifier Selection:	Illuminated front panel pushbuttons
DIM:	Reduces speaker audio level by 10dB
CUT L & CUT R:	Mutes left/right speaker audio
MONO:	Combines left and right audio inputs
PHASE INVERT:	Inverts phase of right audio input
M+S:	Converts stereo input to Middle (sum) and Side (difference) signals
User-Variable Equalisation	
Type:	Parametric
Bands:	Five
Centre Frequency:	200Hz to 18kHz
Bandwidth:	0.25 to 2 octaves
Boost/Cut:	±12dB
Programming:	Via USB/serial control port
Amplifier/Loudspeakers	
Configuration:	Three-way with stereo mid/high-frequency drivers & mono low-frequency driver
Power Output:	2 x 5W (HF) + 20W (LF) with protective limiter
Crossover:	500Hz (3rd order Butterworth)
Distortion (HF Outputs):	< 0.05% (1kHz, 3W output)
Distortion (LF Output):	< 0.05% (100Hz, 6W output)
Noise:	More than 80dB below full output
Volume:	Mute to full volume via front panel rotary control
Balance Trim:	±6dB via front panel rotary control
Peak Acoustic Level:	102dB SPL @ 2ft

Level Metering

Number:	4 x 26-segment tri-colour LED bargraphs
Characteristics:	Selectable by switch from: <ol style="list-style-type: none"> 1. Dual BBC PPM + standard VU 2. BBC PPM 3. EBU PPM 4. Nordic PPM 5. AES/EBU digital PPM 6. DIN PPM 7. Standard VU 8. Extended VU 9. German PPM
Ballistics:	According to selected characteristic
Line-Up Level:	According to selected characteristic
Phase Metering	
Type:	5-segment, indication at 0, 45, 90, 135 and 180 degrees
Remote Control	
USB:	Slave device, 19200 baud
Serial:	RS232, 19200 baud, 3-wire connection
Alarm Outputs:	<ol style="list-style-type: none"> 1. Audio underlevel/fail (latching) 2. Audio overlevel (latching) 3. Sustained phase error (latching) 4. AES/EBU input unlock (non-latching) Open-collector outputs rated at 30V, 50mA maximum Output low/conducting in normal condition (no alarm)
Control Inputs:	<ol style="list-style-type: none"> 1. Mute audio 2. Dim audio 3. Alarm reset Pull-to-ground to activate inputs
Status Indicators	
LIMIT:	Indicates loudspeaker protection limiter is active.
CLIP:	Indicates internal digital clipping due to overlevel.
LOCK:	Indicates lock achieved on selected digital input(s).
OPT:	For future use.

Connectors

Audio Inputs:	8 x XLR 3-pin female (balanced, may be unbalanced)
Audio Outputs:	2 x XLR 3-pin male (balanced, may be unbalanced)
Headphones:	1/4" (6.35mm) A-gauge 3-pole stereo jack socket
USB:	Type B socket
Serial:	D-sub 9-pin female
Remote I/O:	D-sub 15-pin male
Mains Input:	Filtered 3-pin IEC male, continuously rated 85 - 264VAC, 47 - 63Hz, fused, 60W peak, 30W average
Fuse Rating:	Anti-surge fuse 2A 20 x 5mm
Equipment Type	
RM-4C8:	Reference Monitor, 4 LED meters, 8 channel inputs & dual source selectors
Physical Specification	
Dimensions (Raw):	48cm (W) x 30.5cm (D) x 4.4cm (H) (1U) 19" (W) x 12" (D) x 1.73" (H) (1U)
Dimensions (Boxed):	58cm (W) x 52cm (D) x 14cm (H) 22.8" (W) x 20.5" (D) x 5.5" (H)
Weight:	Nett: 4.5kg Gross: 6kg Nett: 10lb Gross: 13.2lb
Options	
RM-HD1:	HD-SDI expansion card
RM-HDE1:	HD-SDI & Dolby® E expansion card
RM-E1X:	HD-SDI Dolby® E decoder XLR expansion card
RM-E1B:	HD-SDI & Dolby® E decoder BNC expansion card



RM-4C8-HD1 Reference Monitor, 4 LED Meters, 8 Channel Inputs & Dual Source Selectors

With RM-HD1 3G/HD/SD-SDI De-Embedder Card



Category: Reference Monitors.

Product Function: Allows the de-embedding of audio channels in a 3G/HD/SD-SDI stream.

Typical Applications: OB truck monitoring of incoming video feed from a sports ground. Post Production monitoring of HD-SD/SDI audio.

Features: Automatic 3G/HD/SD input detection, visual monitoring of all channels in a group, delay of an embedded group with PC configuration.

This is a version of the RM-4C8 with the RM-HD1 expansion card fitted. The expansion card allows the monitoring of embedded non-encoded linear PCM audio channels within a single link 3G/HD/SD-SDI video signal.

The RM-4C8 has individual channel selection for each speaker allowing individual channels in a 5.1 or multichannel mix to be selected for monitoring, e.g. the Centre or LFE channel can be isolated, or Left and Right Rear surround channels.

The expansion board can extract any selected AES/EBU audio group (4 channels) from the video signal and pass them to the main Reference Monitor unit for monitoring. Any group can be selected and can also be

optionally delayed by up to ~300ms by using the Sonifex SCi remote control software. All channels in the selected group can be monitored visually and 2 channels can be selected to be monitored on the speakers.

The input is auto-sensing for either SD, HD or single link 3G input formats and the extraction of embedded audio complies with SMPTE-272 (SD) and SMPTE-299 (HD/3G).

The SDI input is equalized, internally re-clocked and re-transmitted to provide a re-clocked output to pass to external equipment such as another reference monitor.

For the technical specification please refer to the RM-HD1 card itself.



SCI Software Screen for RM-4C8-HD1.





RM-4C8-HDE1 Reference Monitor, 4 LED Meters, 8 Channel Inputs & Dual Source Selectors With De-Embedder & Dolby Decoder Card



Category: Reference Monitors.

Product Function: Allows the de-embedding of audio channels in a 3G/HD/SD-SDI stream and subsequent Dolby E decoding for audible & visual monitoring.

Typical Applications: For taking a satellite feed and monitoring HD-SDI and decoded Dolby E sources.

Features: Dolby metadata display on connected PC, 8 input metering on 4 meters, 3G/HD/SD-SDI de-embedding.

This version of the Reference Monitor is the RM-4C8 with the RM-HDE1 expansion card already fitted. So, it has all of the features of the RM-4C8 as standard together with the ability to de-embed audio from an HD-SDI stream and then decode a Dolby digital audio signal from that de-embedded audio.

The RM-HDE1 adds to the unit a 75ohm HD-SDI input and output on BNC connectors with the output acting as a loop-through of the input.

The monitor can take an HD-SDI input and de-embed audio from any selected audio group, with left and right speakers being able to monitor any 2 channels within that group. The 4 channels in a group are shown on the 4 bar-graph meters. If a Dolby E

or Dolby Digital input is detected on the selected input, the Channels (CHANS) button flashes to indicate that decoding is possible. Pressing the CHANS button displays the Dolby Digital 5.1 or Dolby E 8 channel signal, using the 4 bar-graph meters.

Each meter is split into 2 sections allowing you to view L, R, C, LFE, Ls, Rs for Dolby Digital and an additional Lt, Rt for Dolby E.

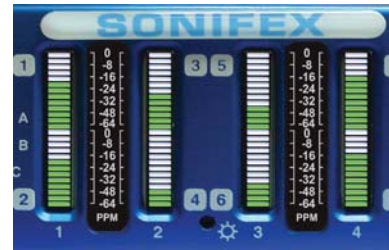

The Programmes (PROGS) button allows any Dolby programmes to be selected and monitored.

Full Dolby Metadata is available using the SCI remote control software. For a more detailed description of Dolby Decoding operation please refer to the Reference Monitor handbook.

With full remote control via GPI, RS232 or USB, a 5 band parametric equaliser, 6 front panel modifier buttons and the ability to take the optional HD-SDI expansion cards, the RM-4C8 is a flexible and versatile monitoring solution.

SONIFEX

www.sonifex.co.uk

UK Office:

Sonifex Ltd

61 Station Road, Irthlingborough,

Northants, NN9 5QE, UK

Tel: +44 (0) 1933 650700

Fax: +44 (0) 1933 650726

Email: sales@sonifex.co.uk

Australian Office:

Sonifex Pty Ltd

Unit 12/6 Leighton Place, Hornsby,

New South Wales 2077, Australia

Tel: +61 (2) 9987 0499

Fax: +61 (2) 9476 4950

Email: sales@innescorp.com.au