



Redbox RB-MTV1  
Contribution Voiceover  
Monitor With Talkback

# User Handbook



# RB-MTV1 USER HANDBOOK



## RB-MTV1 USER HANDBOOK

This handbook is for use with the following product:  
Redbox RB-MTV1 Contribution Voiceover Monitor With Talkback

©Sonifex Ltd, 2009  
All Rights Reserved  
Revision 1.01, January 2009

Sonifex Ltd, 61, Station Road, Irthlingborough,  
Northants, NN9 5QE, England.  
Tel: +44 (0)1933 650 700  
Fax: +44 (0)1933 650 726  
Email: [sales@sonifex.co.uk](mailto:sales@sonifex.co.uk)  
Website: <http://www.sonifex.co.uk>

Information in this document is subject to change without notice and does not represent a commitment on the part of the vendor. Sonifex Ltd shall not be liable for any loss or damage whatsoever arising from the use of information or any error contained in this manual.

No part of this manual may be reproduced or transmitted in any form or by any means, electronic or mechanical, including photocopying, recording, information storage and retrieval systems, for any purpose other than the purchaser's personal use, without the express written permission of Sonifex Ltd. Unless otherwise noted, all names of companies, products and persons contained herein are part of a completely fictitious adaptation and are designed solely to document the use of Sonifex product.



<b>Warranty</b>	<b>i</b>
Warranty and Liability	i
Unpacking the RB-MTV1	iii
Returning the Warranty Card	iii
<b>Safety Information</b>	<b>iv</b>
Safety of Mains Operated Equipment	iv
Voltage Setting Checks	iv
Fuse Rating	iv
Power Cable and Connection	iv
Ordering the Correct Mains Lead	v
<b>Installation Information</b>	<b>v</b>
Atmosphere	v
Electromagnetic Radiation	v
Fitting Redboxes	v
WEEE & RoHS Directives - Sonifex Statement	vi
<b>RB-MTV1 Contribution Voiceover Monitor With Talkback</b>	<b>1</b>
Introduction	1
System Block Diagram	2
Front Panel Controls & Indicators	3
MIC Button	3
LED Meter	3
Limit LED	3
TALK Button	3
Headphone Level Controls	3
Headphone Output	3
<b>Rear Panel Connections &amp; Operation</b>	<b>4</b>
Headphone Output	4
Output 2 With Mic/Line Switch	4
Output 1 With Mic/Line Switch	4
Limiter On/Off Switch	5
Limiter Level Control	5
Mic Input Gain Control	5
Microphone Input	6
Remote Inputs & Outputs	6
DIP Switch Configuration Settings (Rear Panel)	6
<i>Microphone Options</i>	6
<i>Switching Options</i>	7
<i>Metering Option</i>	7
<i>Remote Option</i>	7
<i>Output Option</i>	7
DIP Switch Settings (On The Underside Of The Unit)	
For Headphone Channel Mix Options	7
<b>Technical Specification For RB-MTV1</b>	<b>8</b>



**CONTENTS**

# FIGURES & TABLES



## FIGURES & TABLES

### Figures

Fig A: Packing List	iii
Fig B: Power Connections	iv
Fig C: Mains Lead Table	v
Fig D: RB-RK3 Large Redbox Rear Rack-mount Kit	v
Fig 1: RB-MTV1 Front Panel	1
Fig 2: RB-MTV1 Block Diagram	2
Fig 3: MIC Button	3
Fig 4: LED Meter	3
Fig 5: Limit LED	3
Fig 6: TALK Button	3
Fig 7: Headphone Level Controls	3
Fig 8: RB-MTV1 Rear Panel Connections	4
Table A: Rear Panel DIPSwitch Configuration Settings	6
Fig 9: Underside of RB-MTV1 Showing Headphone Channel Mix DIPSwitches	7
Table B: Underside DIPSwitch Settings For Headphone Channel Mix Options	8



## Warranty

### Warranty and Liability

**Important: the purchaser is advised to read this clause**

- (a) The Company agrees to repair or (at its discretion) replace Goods which are found to be defective (fair wear and tear excepted) and which are returned to the Company within 12 months of the date of despatch provided that each of the following are satisfied:
- (i) notification of any defect is given to the Company immediately upon its becoming apparent to the Purchaser;
  - (ii) the Goods have only been operated under normal operating conditions and have only been subject to normal use (and in particular the Goods must have been correctly connected and must not have been subject to high voltage or to ionising radiation and must not have been used contrary to the Company's technical recommendations);
  - (iii) the Goods are returned to the Company's premises at the Purchaser's expense;
  - (iv) any Goods or parts of Goods replaced shall become the property of the Company;
  - (v) no work whatsoever (other than normal and proper maintenance) has been carried out to the Goods or any part of the Goods without the Company's prior written consent;
  - (vi) the defect has not arisen from a design made, furnished or specified by the Purchaser;
  - (vii) the Goods have been assembled or incorporated into other goods only in accordance with any instructions issued by the Company;
  - (viii) the defect has not arisen from a design modified by the Purchaser;
  - (ix) the defect has not arisen from an item manufactured by a person other than the Company.

In respect of any item manufactured by a person other than the Company, the Purchaser shall only be entitled to the benefit of any warranty or guarantee provided by such manufacturer to the Company.

- (b) In respect of computer software supplied by the Company the Company does not warrant that the use of the software will be uninterrupted or error free.



**WARRANTY**

# WARRANTY



## WARRANTY

- (c) The Company accepts liability:
  - (i) for death or personal injury to the extent that it results from the negligence of the Company, its employees (whilst in the course of their employment) or its agents (in the course of the agency);
  - (ii) for any breach by the Company of any statutory undertaking as to title, quiet possession and freedom from encumbrance.
- (d) Subject to conditions (a) and (c) from the time of despatch of the Goods from the Company's premises the Purchaser shall be responsible for any defect in the Goods or loss, damage, nuisance or interference whatsoever consequential economic or otherwise or wastage of material resulting from or caused by or to the Goods. In particular the Company shall not be liable for any loss of profits or other economic losses. The Company accordingly excludes all liability for the same.
- (e) At the request and expense of the Purchaser the Company will test the Goods to ascertain performance levels and provide a report of the results of that test. The report will be accurate at the time of the test, to the best of the belief and knowledge of the Company, and the Company accepts no liability in respect of its accuracy beyond that set out in Condition (a).
- (f) Subject to Condition (e) no representation, condition, warranty or other term, express or implied (by statute or otherwise) is given by the Company that the Goods are of any particular quality or standard or will enable the Purchaser to attain any particular performance or result, or will be suitable for any particular purpose or use under specific conditions or will provide any particular capacity, notwithstanding that the requirement for such performance, result or capacity or that such particular purpose or conditions may have been known (or ought to have been known) to the Company, its employees or agents.
- (g)
  - (i) To the extent that the Company is held legally liable to the Purchaser for any single breach of contract, tort, representation or other act or default, the Company's liability for the same shall not exceed the Price of the Goods.
  - (ii) The restriction of liability in Condition (g)(i) shall not apply to any liability accepted by the Seller in Condition (c).
- (h) Where the Goods are sold under a consumer transaction (as defined by the Consumer Transactions (Restrictions on Statements) Order 1976) the statutory rights of the Purchaser are not affected by these Conditions of Sale.



### Unpacking the RB-MTV1

The RB-MTV1 is shipped with the following equipment. Please check your packaging to ensure that you have all of the items below. If anything is missing, please contact the supplier of your equipment immediately.

Item	Quantity RB-MTV1
RB-MTV1	1
IEC Mains lead fitted with moulded mains plug	1
Handbook and warranty card	1

Fig A: Packing List

Each RB-MTV1 is shipped in protective packaging and should be inspected for damage before use. Where an item is found to have transit damage, notify the carrier immediately with all the relevant details of the shipment. Packing materials should be kept for inspection and also for if the product needs to be returned.

### Returning the Warranty Card

In order to register the date of purchase so that we can keep you informed of any design improvements or modifications, it is important to complete the warranty registration document that is enclosed and return it to Sonifex Ltd in the UK.

For your own records you should write down the serial number (which can be found on the rear of the RB-MTV1).

Serial Number	.....
---------------	-------



WARRANTY

# SAFETY & INSTALLATION INFORMATION



## Safety Information

### Safety of Mains Operated Equipment



This equipment has been designed to meet the safety regulations currently advised in the country of purchase and it conforms to the safety regulations specified by use of the CE Mark.

**Warning :** There are no user serviceable parts inside the equipment. If you should ever need to look inside the unit, always disconnect the mains supply before removing the equipment covers.

### Voltage Setting Checks

Ensure that the machine operating voltage is correct for your mains power supply by checking the box in which your Redbox was supplied. The voltage is shown on the box label. The available voltage settings are 115V, or 230V. Please note that all Redboxes are either switchable between 115V and 230V, or have a universal power supply.

### Fuse Rating

The RB-MTV1 is supplied with a single fuse in the live conducting path of the mains power input. For reasons of safety it is important that the correct rating and type of fuse is used. Incorrectly rated fuses could present a possible fire hazard, under equipment fault conditions. The fuse rating for the RB-MTV1 is:

230V operation	100mA, 5 x 20mm SB
115 V operation	200mA, 5 x 20mm SB

The active fuse is fitted on the outside rear panel of the unit.

### Power Cable and Connection

An IEC power connector is supplied with the RB-MTV1 which has a moulded plug attached – this is a legal requirement. If no moulded plug has been supplied with your RB-MTV1, please contact your supplier, because an IEC connector is always supplied from the Sonifex factory.

If for any reason, you need to use the RB-MTV1 with a different power cable, you should use the following wiring guidelines.

Wire Colour	Connection
Green, or green and yellow	Earth (E)
Blue, or Black	Neutral (N)
Brown, or Red	Live (L)

Fig B: Power Connections

Connect the equipment in accordance with the connection details and before applying power to the unit, check that the machine has the correct operating voltage for your mains power supply.







## Ordering the Correct Mains Lead

When ordering a Redbox from Sonifex, it is helpful if you can specify your required operating voltage and mains lead. After the product code add:





UK, for 230V, UK 3 pin to IEC lead	
EC, for 230V, European Schuko 2 pin to IEC lead	
US, for 115V, 3 pin to IEC lead	
AU for 230V, Australasian 3 pin to IEC lead	

Fig C: Mains Lead Table

E.g. order RB-MTV1 UK for a UK IEC lead to be supplied.

## Installation Information

### Atmosphere

The units should be installed in an area that is not subject to excessive temperature variation (<0°C, >50°C), moisture, dust or vibration.

### Electromagnetic Radiation

The cover is connected to earth by means of the fixing screws. It is essential to maintain this earth ground connection to ensure a safe operating environment and provide electromagnetic shielding.

### Fitting Redboxes

Redboxes can be fixed to the underside of a mixing desk, or other surfaces using 4.2mm holes in the sides and fixed with 2 x M4 screws or 2 x No. 6 countersink wood screws.

They can also be rack-mounted, with either the front, or rear of the Redbox positioned at the front of the rack:

**Rear Mounting The RB-MTV1:** The **RB-RK3** 1U rear panel rack kit can be used for large Redboxes such as the RB-MTV1.



Fig D: RB-RK3 Large Redbox Rear Rack-mount Kit

**Note:** When fitting the rear-mounting rack-kits, a notch has been left on the inside of the right-hand rack-piece for the mains cable to pass through. Make sure that the mains cable has been put through the notch before attaching the right hand rack-piece.

# SAFETY & INSTALLATION INFORMATION



## SAFETY & INSTALLATION INFORMATION

### WEEE & RoHS Directives - Sonifex Statement



The Waste Electrical and Electronic Equipment (WEEE) Directive was agreed on 13 February 2003, along with the related Directive 2002/95/EC on Restrictions of the use of certain Hazardous Substances in electrical and electronic equipment (RoHS).

The **Waste Electrical and Electronic Equipment Directive (WEEE)** aims to minimise the impacts of electrical and electronic equipment on the environment during their life times and when they become waste. It applies to a huge spectrum of products. It encourages and sets criteria for the collection, treatment, recycling and recovery of waste electrical and electronic equipment. All products manufactured by Sonifex Ltd have the WEEE directive label placed on the case. It gives a contact for individuals who are unsure about the correct procedure when the product has reached its “end of use”.

Sonifex Ltd will be happy to give you information about local organisations that can reprocess the products, or alternatively all products that have reached “end of use” can be returned to Sonifex and will be reprocessed correctly free of charge.

Sonifex Ltd has phased out the use of certain hazardous substances identified in the European Union’s **Restriction of Hazardous Substances (RoHS)** directive. The RoHS directive limits the use of certain hazardous substances currently used in EEE manufacture, including lead, mercury, cadmium, hexavalent chromium, and halide-containing compounds PBB (polybrominated biphenyl) and PBDE (polybrominated diphenyl ether). Elimination of these substances will result in more environmentally friendly recycling of electronic equipment. For the products which Sonifex manufacture, the main area where products were affected was in the use of lead for manufacturing and assembling electronics circuit boards.

Sonifex Ltd practices lead-free (LF) manufacturing processes. LF solder is used on the surface-mount PCB manufacturing processes and for hand soldering. The printed circuit boards (PCBs) used are either gold plated, or immersion tin plated, both of which use no lead. Historically the PCBs were hot air solder levelled (HASL) PCBs which used tin/lead based solder.

The manufacturing processes include the assembly of purchased components from various sources. Product is offered as RoHS compliant, or LF, only after sufficient evidence is received from the component manufacturers that their components are RoHS compliant. Sonifex Ltd relies solely on the distributor, or manufacturer, of the components for identification of RoHS compliance. Thus whilst every effort is made to ensure compliance, Sonifex Ltd makes no warranty, or certification, or declaration of compliance concerning said components.

Sonifex Ltd defines “Lead Free” as pertaining to any product, which has been manufactured by Sonifex Ltd using components which have been declared by the manufacturers as “Lead Free”. All statements by Sonifex Ltd of RoHS compliance are based on component manufacturer documentation.

**RB-MTV1 Contribution Voiceover Monitor With Talkback**

**Introduction**

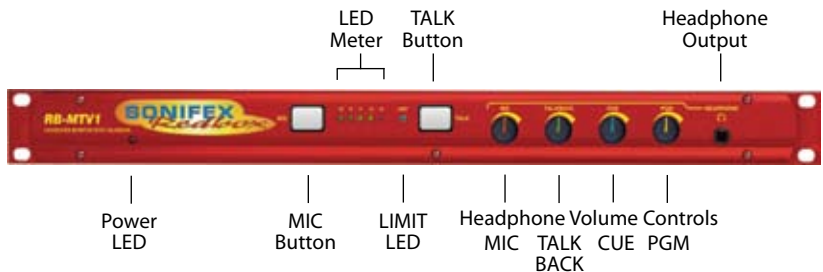

Fig 1: RB-MTV1 Front Panel

The RB-MTV1 contribution voiceover monitor is a 1U rack-mount designed to be used in voice-over booths, news booths, commentary locations, for continuity announcements and for any other similar applications where voice needs to be added to programme content and then monitored. Programme feeds, auxiliary feeds and a talkback feed can be taken in and monitored.

The RB-MTV1 has a microphone input, two main mono outputs, two external stereo monitoring inputs plus a 4-wire. It has a mono microphone input on XLR with switched coarse gain and variable fine gain control using a multi-turn preset potentiometer to give an overall gain range from +20dB to +80dB. There is also a switched LF rumble filter, switched +48V phantom power and switched level limiting control. A rear-panel multi-turn preset potentiometer allows adjustment of the threshold at which the limiter begins to operate, from -8dBu to +26dBu. There is an indication of the limiter activity using a blue LED and the microphone level is monitored by a simple 5 LED meter. The meter can be configured to either show the MIC signal activity in normal operation, i.e. when TALK is pressed the meter is off, or the meters can permanently show the MIC activity even when the TALK button is on or the MIC button is off.

There is a mono balanced TALKBACK input on XLR. There are two balanced XLR stereo inputs, CUE and programme (PGM) each with a 10dB input gain switch to facilitate the use of unbalanced sources such as from PC audio cards, domestic CD players, etc.

Each of these inputs, MIC, TALKBACK, CUE and PGM can be mixed and monitored in the front and rear headphone outputs with individual volume controls. Which of the inputs is presented to the headphone outputs can be configured using two banks of DIPswitches on the underside of the unit, one bank for audio that is heard in the left ear piece and one bank for audio monitored in the right ear piece. For example, the left and right PGM inputs can be sent to the right ear-piece and all other signals to the left ear-piece, or the TALK signal could be sent to the right ear-piece and all other signals to both ear-pieces. In this way, you can configure the unit for your particular application on installation. If a presenter doesn't like to hear themselves in their headphones when using the TALK button, there is also a DIPswitch option to mute the mic signal to the headphones.



# 1

## INTRODUCTION



## INTRODUCTION

There are two mono balanced outputs. The processed microphone signal is fed to the two outputs when the electronically latching front panel MIC button is active - the button illuminates when active.

The two main outputs can be independently switched to be at 'Line' or 'Mic' level outputs using rear panel push switches. Setting the output to a microphone level allows the unit to be inserted into the microphone channel of a mixer. There is an option to permanently enable the MIC button, even when remotely controlled, for occasions when you always want the MIC channel left open. Additionally, there is an option to mix the CUE input as a mono feed to the outputs permanently.

The front panel TALK button is a momentary push switch that routes the processed microphone signal to the "LAZY" TALK output, whilst disconnecting it from the main outputs, allowing the operator to talk to a colleague. This enables the unit to be used as a talkback intercom between two or more studios.

There is a rear panel remotes connector giving remote control of the two front panel MIC and TALK buttons and opto-isolated tallies of their status.

A red LED on the front panel of the unit indicates when power is present.

### System Block Diagram

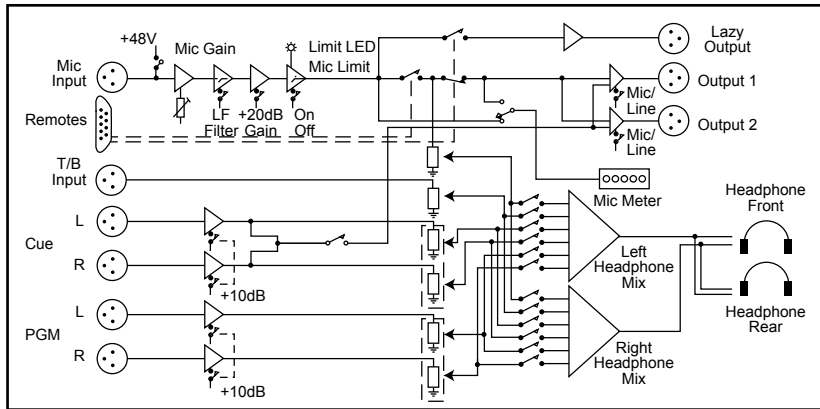

Fig 2: RB-MTV1 Block Diagram

## Front Panel Controls & Indicators

### MIC Button

This is an illuminated electronically latching push switch that routes microphone audio to outputs 1 and 2, provided that the TALK button is not also pressed. The button illuminates red when the MIC function is active. Push the button again to unlatch it.



Fig 3: MIC Button

### LED Meter

This is a 5 way LED meter with the following level indicators: -12dB (green), -6dB (green), 0dB (yellow), +3dB (yellow), +6dB (red). The LED meter source is selected by the back panel dip switch.



Fig 4: LED Meter

### Limit LED

This 3mm blue LED illuminates when the limiter circuit is operating. A rear-panel multi-turn preset potentiometer allows adjustment of the threshold at which the limiter begins to operate, from -8dBu to +26dBu.



Fig 5: Limit LED

### TALK Button

The TALK button is a momentary push switch that routes mic audio to the lazy talkback output, whilst disconnecting it from the main outputs, allowing the operator to talk to a colleague. The button illuminates green when the TALK function is active.



Fig 6: TALK Button

### Headphone Level Controls

There are four volume control knobs, one for each of the audio sources MIC, TALKBACK, CUE and PGM, that determine the level of each audio source that is mixed into the front and rear panel headphone outputs.



Fig 7: Headphone Level Controls

As well as being able to alter the volume of the sources presented to the headphones, using DIPswitches on the underside, the RB-MTV1 can be configured to alter which of the inputs is presented to the headphone outputs, to enable customization of the unit for your monitoring application.

### Headphone Output

The front panel headphone output is a 1/4" (6.35mm) jack socket and is a parallel connection of that on the rear, designed to drive 150mW into 32Ω to 600Ω professional headphones.



### Rear Panel Connections & Operation

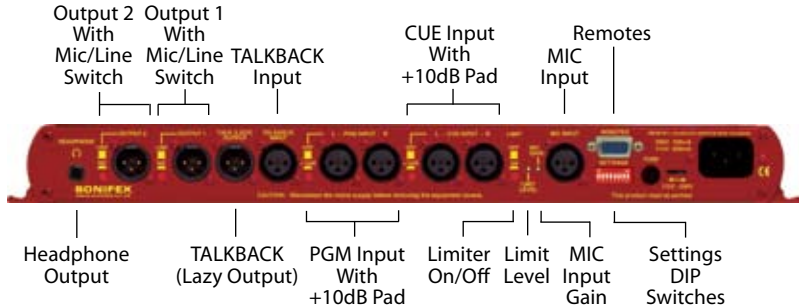

Fig 8: RB-MTV1 Rear Panel Connections

#### Headphone Output

The rear panel headphone output is a 1/4" (6.35mm) jack socket and is a parallel connection of that on the front, designed to drive 150mW into 32 $\Omega$  to 600 $\Omega$  professional headphones.

#### Output 2 With Mic/Line Switch

The XLR 3 pin plug used for the mono mic/line output is electronically balanced and has an output impedance of <50 $\Omega$  bridging in line mode and 100 $\Omega$  nominal in mic mode. The XLR has the following connections:

- Pin 1: Screen.
- Pin 2: Phase.
- Pin 3: Non-phase.

Depressing the MIC/LINE button converts the output to a mic level and impedance for insertion into a mic channel. The default state for this output is LINE.

#### Output 1 With Mic/Line Switch

The XLR 3 pin plug used for the mono mic/line output is electronically balanced and has an output impedance of <50 $\Omega$  bridging in line mode and 100 $\Omega$  nominal in mic mode. The XLR has the following connections:

- Pin 1: Screen.
- Pin 2: Phase.
- Pin 3: Non-phase.

Depressing the MIC/LINE button converts the output to a mic level and impedance for insertion into a mic channel. The default state for this output is LINE.

#### TALKBACK (LAZY) Output

The XLR 3 pin plug used for the mono lazy talkback output is electronically balanced and has an impedance of <50 $\Omega$  bridging. The XLR has the following connections:

- Pin 1: Screen.
- Pin 2: Phase.
- Pin 3: Non-phase.

This output is activated by pressing the "TALK" button on the front panel and is intended to be used as a talkback intercom between two units.

## TALKBACK Input

The mono talkback line level input is electronically balanced and is routed directly to the TALKBACK headphone level control on the front panel, to adjust the mix into the headphones. The XLR socket has the following connections:

- Pin 1: Screen.
- Pin 2: Phase.
- Pin 3: Non-phase.

## PGM Inputs (Left and Right) With 10dB Pad

The left and right PGM inputs are electronically balanced line level inputs with an impedance of  $>20k\Omega$  and a gain boost switch (+10dB) for use with equipment at domestic audio levels. The XLR sockets have the following connections:

- Pin 1: Screen.
- Pin 2: Phase.
- Pin 3: Non-phase.

The PGM audio is routed directly to the PGM headphone level control on the front panel, to adjust the mix into the headphones.

## CUE Inputs (Left and Right) With 10dB Pad

The left and right CUE inputs are electronically balanced line level inputs with an impedance of  $>20k\Omega$  and a gain boost switch (+10dB) for use with semi-pro equipment at lower audio levels. The XLR sockets have the following connections:

- Pin 1: Screen.
- Pin 2: Phase.
- Pin 3: Non-phase.

The CUE audio is routed directly to the CUE headphone level control on the front panel, to adjust the mix into the headphones. It can also be mono mixed to the 2 main outputs using DIPSwitch 8 on the rear panel.

## Limiters On/Off Switch

This is a latching push switch to switch the microphone limiter on or off. The default position for this switch is off.

## Limiters Level Control

The limit level control is a multi-turn preset potentiometer to set the maximum output level when the limiter is enabled. The level can be set between -8dBu and +26dBu and as standard is set at +8dBu.

## Mic Input Gain Control

This is a multi-turn preset potentiometer to adjust the gain of the microphone input. The gain ranges from +20dB to +80dB when used with DIPSwitch 1 on the rear panel.



### Microphone Input

The microphone input is an electronically balanced mono mic level input that is routed directly to the MIC headphone level control on the front panel, to adjust the mix into the headphones. The microphone audio appears on the two main outputs whenever the electronically latching MIC button has been pressed and illuminated. The microphone signal is switchable on to the 'lazy' talkback output by pressing the TALK button. The XLR socket has the following connections:

Pin 1: Screen.

Pin 2: Phase.

Pin 3: Non-phase.

### Remote Inputs & Outputs

The 9-way 'D' type socket offers the following connections:

Pin 1: Remote Mic switch input (make to common pin 6).

Pin 2: Mic indicator opto-coupled NPN collector output.

Pin 3: Talk switch (make to common pin 8)

Pin 4: Talk indicator opto-coupled NPN collector output.

Pin 5: +5V feed @ 0.2A maximum.

Pin 6: Mic common 0V.

Pin 7: Mic indicator opto-coupled NPN emitter output.

Pin 8: Talk common 0V.

Pin 9: Talk indicator opto-coupled NPN emitter output.

### DIPSwitch Configuration Settings (Rear Panel)

DIPSwitch Setting No	Function When DIPSwitch is ON	Default Setting
1	Plus 20dB Mic Gain.	OFF
2	LF Filter Off.	ON
3	Phantom Power On.	OFF
4	Mic Mute in Headphones On Talk.	OFF
5	Enable Permanent Mic On.	OFF
6	Mic Meter Permanent.	OFF
7	Latched Remote Input on Mic Switch.	ON
8	Mono Mix of Cue Input to Mono Outputs.	OFF

Table A: Rear Panel DIPSwitch Configuration Settings

### Microphone Options

Options are available to add phantom power at +48V to the microphone input (DIPSwitch 3 ON), switch a low frequency rumble filter in (DIPSwitch 3 OFF) and to add an additional 20dB of gain to the microphone input: The microphone gain range is adjustable from +20dB to +80dB and this is done as +20dB to +60dB via the MIC GAIN rotary potentiometer with DIPSwitch 1 OFF, or +40dB to +80dB via rotary potentiometer with DIPSwitch 1 ON.





**Switching Options**

**TALK button** - On pressing the TALK button, set DIPSwitch 4 to ON to mute the microphone signal to the headphones, for the situation where you are using talkback and don't want to hear your own voice in the headphones.

**MIC button** - The MIC button can be permanently latched, i.e. always on, by setting DIPSwitch 5 to ON. In this mode, the microphone can not be switched off or remotely switched off, but all other operation is normal, for example, pressing the TALK button mutes the microphone to the Outputs 1 and 2. This is useful in situations where you need to leave the unit unattended and want to ensure that the microphone is always on, e.g. for covert operations, or where the operator may be unfamiliar with the unit's operation.

**Metering Option**

The meter can be made to permanently show the level of the MIC input. With DIPSwitch 6 set to OFF, the metering is disabled whilst the TALK button is pressed. With DIPSwitch 6 set to ON, the metering permanently shows the microphone input level.

**Remote Option**

The Remote Mic switch input (Pin 1 of the Remotes) can be controlled by a latching or momentary switch. With DIPSwitch 7 OFF, a momentary switch will operate it. With DIPSwitch 7 ON, the remote switch needs to be a latching type.

**Output Option**

By setting DIPSwitch 8 to ON, the CUE stereo input can be mono mixed to Outputs 1 and 2.

**DIP Switch Settings (On The Underside Of The Unit)  
For Headphone Channel Mix Options**

The DIPSwitches on the underside of the unit can be used to define which of the sources (MIC, TALKBACK, PGM and CUE) are sent to which side of the headphone output (left or right).. There are two sets of switches; the ones on the left represent the left earpiece of the headphones, the right switches represent the right earpiece. Setting the DIPSwitch to ON enables the selected source to the selected earpiece.

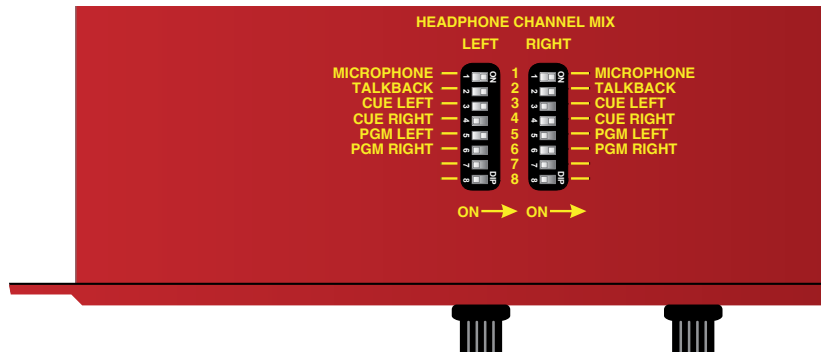

Fig 9: Underside of RB-MTV1 Showing Headphone Channel Mix DIPSwitches



DIP Switch Setting No	Source/Input	Default Setting (Left SW8)	Default Setting (Right SW9)
1	Microphone	ON	ON
2	Talkback	ON	ON
3	Cue Left	ON	OFF
4	Cue Right	OFF	ON
5	PGM Left	ON	OFF
6	PGN Right	OFF	ON
7	-	N/A	N/A
8	-	N/A	N/A

Table B: Underside DIP Switch Settings For Headphone Channel Mix Options

### Technical Specification For RB-MTV1

Input Impedance:	2k $\Omega$ nominal balanced MIC input >20k $\Omega$ all other inputs.
Maximum Input Level:	-10dBu MIC input +26dBu TALK, CUE & PGM inputs
Mic Gain Range:	Adjustable +20dB to +80dB: +20dB to +60dB with Settings DIP Switch 1 OFF +40dB to +80dB with Settings DIP Switch 1 ON
E.I.N.:	130dB
Common Mode Rejection:	>60dB typically
Low Frequency Roll-Off:	125Hz @ 6dB/octave
Distortion:	0.01% THD @ 1kHz, ref +8dBu output
Phantom Power:	+48V
Limiter Threshold:	Adjustable -8dBu to +26dBu
Output Impedance:	<50 $\Omega$ in LINE mode, 100 $\Omega$ nominal in MIC mode
Maximum Output Level:	+26dBu balanced outputs in LINE mode -18dBu in MIC mode
Headphone Output Level:	Drives 150mW into 32 $\Omega$ to 600 $\Omega$ headphones
Frequency Response:	20Hz to 20KHz $\pm$ 0.1dB (ref 1KHz)



**Rear Panel Connections**

MIC Input:	1 x XLR 3 pin female (Balanced)
TALKBACK Input:	1 x XLR 3 pin female (Balanced)
CUE Inputs:	2 x XLR 3 pin female (Balanced)
PGM Inputs:	2 x XLR 3 pin female (Balanced)
Mic/Line Output 1:	1 x XLR 3 pin male (Balanced)
Mic/Line Output 2:	1 x XLR 3 pin male (Balanced)
TALK (LAZY) Output:	1 x XLR 3 pin male (Balanced)
Headphone Outputs:	2 x ¼" (6.35mm) A-gauge 3-pole stereo jack sockets
Remote I/O Port:	9-way 'D'-type socket
Mains Input:	Filtered IEC, 110V-120V, or 220-240V switchable, fused, 9W maximum
Fuse Rating:	Anti-surge fuse 100mA 20 x 5mm (230VAC) Anti-surge fuse 250mA 20 x 5mm (115VAC)

**Equipment Type**

RB-MTV1:	Contribution Voiceover Unit With Talkback
----------	---

**Physical Specification**

Dimensions	48cm (W) x 10.8cm (D) x 4.3cm (H) (Raw): 19" (W) x 4.3" (D) x 1.7" (H) (1U)	
Dimensions	59cm (W) x 20.5cm (D) x 6cm (H) (Boxed): 21" (W) x 8" (D) x 2.4" (H)	
Weight :	Nett: 1.3kg      Gross: 1.9kg	
	Nett: 2.9lbs      Gross: 4.2lbs	

**Accessories**

RB-RK3:	1U Rear panel rack kit for large Redboxes
---------	---

# SONIFEX

[www.sonifex.co.uk](http://www.sonifex.co.uk)

t:+44 (0)1933 650 700

f:+44 (0)1933 650 726

[sales@sonifex.co.uk](mailto:sales@sonifex.co.uk)

